

JRC SCIENTIFIC AND POLICY REPORTS

Design Guidelines for Connections of Precast Structures under Seismic Actions

Paolo Negro and Giandomenico Toniolo
Editors

2012



Report EUR 25377 EN

European Commission
Joint Research Centre
Institute for the Protection and Security of the Citizen

Contact information

Paolo Negro

Address: Joint Research Centre, Via Enrico Fermi 2749, TP 480, 21027 Ispra (VA), Italy

E-mail: paolo.negro@jrc.ec.europa.eu

Tel.: +39 0332 78 5452

Fax: +39 0332 78 9049

<http://elsa.jrc.ec.europa.eu/>

<http://eurocodes.jrc.ec.europa.eu/>

This publication is a Reference Report by the Joint Research Centre of the European Commission.

Legal Notice

Neither the European Commission nor any person acting on behalf of the Commission is responsible for the use which might be made of this publication.

Europe Direct is a service to help you find answers to your questions about the European Union

Freephone number (*): 00 800 6 7 8 9 10 11

(*) Certain mobile telephone operators do not allow access to 00 800 numbers or these calls may be billed.

A great deal of additional information on the European Union is available on the Internet.

It can be accessed through the Europa server <http://europa.eu/>.

JRC71599

EUR 25377 EN

ISBN 978-92-79-25250-1

ISSN 1831-9424

doi:10.2777/37605

Luxembourg: Publications Office of the European Union, 2012

© European Union, 2012

Reproduction is authorised provided the source is acknowledged.

Printed in Italy

FOREWORD

This document has been drafted within Work-Package WP6, “Derivation of design rules” of the SAFECAST Project (FP7-SME-2007-2 Programme - Grant agreement n. 218417, 2009).

The SAFECAST project (Performance of Innovative Mechanical Connections in Precast Building Structures under Seismic Conditions) is a comprehensive research and development action performed by a group of European associations of precast element producers and industrial partners with the assistance of a group of RTD providers.

The industrial partners were: ASSOBETON, National Italian Association of Precast Concrete Producers, Milan, Italy, represented by Dr. Antonella Colombo; ANDECE, Asociación Nacional de Prefabricados y Derivados del Cemento, Madrid, represented by Dr. Alejandro López Vidal; ANIPB, National Portuguese Association of Precast Concrete Producers, represented by Ms. Marcia Gonçalves; SEVIPS, Association of Greek Concrete Precast Industries, represented by Prof. Spyridion Tsoukantas; TPCA, Turkish Precast Concrete Association, Ankara, represented by Mr. Bulent Tokman; Labor srl, Rome, represented by Mr. Paolo De Stefanis; DLC srl, Milan, represented by Mr. Alberto Dal Lago; Prelosar, Logroño, Spain, represented by Mr. José Antonio Alba Irurzun; LU.GE.A Spa, Rome, represented by Mr. Fabio Ciaroni; Halfen GmbH, Langenfeld, Germany, represented by Mr. Stefano Terletti.

Dr. Antonella Colombo served as the coordinator of the SAFECAST project.

The RTD providers were: ELSA Laboratory, Institute for the Protection and Security of the Citizen, Joint Research Centre of the European Commission, represented by Dr. Paolo Negro; Politecnico di Milano, represented by Prof. Giandomenico Toniolo; National Technical University of Athens, represented by Prof. Ioannis Psycharis; Istanbul Technical University, represented by Prof. Faruk Karadogan; Laboratorio Nacional de Engenharia Civil, Lisboa, represented by Dr. Ema Coelho; University of Ljubljana, represented by Prof. Matej Fishinger.

Dr. Paolo Negro and Prof. Giandomenico Toniolo were charged with the technical management of the SAFECAST project and Prof. Toniolo was the Work-Package leader for the Work-Package WP6 “Derivation of design rules”, of which this document represents the final outcome.

The guidelines given in the following clauses have a theoretical derivation supported by the experimental results of the testing campaigns performed within the Work-Packages WP2, “Experimental activity on new and existing connections” and WP4, “Experimental assessment on real structures” as well as by the numerical simulations performed within Work Package WP3, “Development of analytical models” and WP5, “Numerical model validation”. General know-how on production practice and international literature on the subject have been also considered.

EXECUTIVE SUMMARY

This document represents a set of practical guidelines for the design of the mechanical connections in precast elements under seismic actions.

As a final outcome of the project SAFECAST, the document covers all the types of connections which were studied, experimentally as well as numerically, as a part of the project. However, by integrating the knowledge acquired during the project with the general state-of-the-art knowledge existing in the literature, the guidelines were extended to a potentially exhaustive set of connection typologies. Guidelines are also provided for defining the actions to be used in design.

These guidelines can be used as a reference for designing the connections of precast structures under seismic actions whenever neither specific norms nor mandatory provisions exist.

The guidelines do not cover the specific case of the connections of cladding elements, a problem which might deserve a specific study and might be the objective of a future research project.

List of content

0. GENERAL

- 0.1 Scope
- 0.2 Terminology
- 0.3 Properties
- 0.4 Classification
- 0.5 Bibliography

1. FLOOR-TO-FLOOR CONNECTIONS (ORDER 1)

- 1.1 Cast-in-situ topping
- 1.2 Cast-in-situ joints
- 1.3 Welded steel connections
- 1.4 Bolted steel connections

2. FLOOR-TO-BEAM CONNECTIONS (ORDER 2)

- 2.1 Cast-in-situ joints
- 2.2 Supports with steel angles
- 2.3 Supports with steel shoes
- 2.4 Welded supports
- 2.5 Hybrid connections

3. BEAM-TO-COLUMN CONNECTIONS (ORDER 3)

- 3.1 Cast-in-situ connections
- 3.2 Connections with dowels
- 3.3 Connections with mechanical couplers
- 3.4 Hybrid connections

4. COLUMN-TO-FOUNDATION CONNECTIONS (ORDER 5)

- 4.1 Pocket foundations
- 4.2 Foundations with protruding bars
- 4.3 Connections with bolted sockets
- 4.4 Connections with bolted flanges
- 4.5 Connections with mechanical couplers

5. CALCULATION OF ACTION

- 5.1 General criteria
- 5.2 Capacity design

ANNEX A: Protocol for connection testing

0. GENERAL

Any type of connection shall be experimented with an initial type testing in order to quantify its strength and possibly the other properties that affect its seismic behaviour. From this experimentation a design model may be deduced, by means of which a verification by calculation can be applied on the different connections of the same type.

For a specific application one can refer to the available results of previous experimentations like those provided in the following clauses or in other reliable documents such as official regulations (Eurocodes, CEN product standards and Technical specifications, ...).

0.1 Scope

The present document refers to connections in precast frame systems, either for one-storey or multi-storey buildings. The connections for all orders of joints are considered. Large wall panel and three dimensional cell systems are not considered.

According to the position in the overall construction and of the consequent different structural functions, the following seven orders of joints are considered:

- 1 – *mutual joints between floor or roof elements (floor-to-floor)* that, in the seismic behaviour of the structural system, concern the diaphragm action of the floor;
- 2 – *joints between floor or roof elements and supporting beams (floor-to-beam)* that give the peripheral constraints to the floor diaphragm in its seismic behaviour;
- 3 – *joints between beam and column (beam-to-column)* that shall ensure in any direction the required degree of restraint in the frame system;
- 4 – *joints between column segments (column-to-column)* used for multi-storey buildings usually for dual wall braced systems;
- 5 – *joints between column and foundation (column-to-foundation)*, able to ensure in any plane a fixed full support of the column;
- 6 – *fastenings of cladding panels to the structure (panel-to-structure)* that shall ensure the stability of the panels under the high forces or the large drifts expected under seismic action;
- 7 – *joints between adjacent cladding panels (panel-to-panel)* possibly used to increase the stiffness of the peripheral wall system and provide an additional source of energy dissipation.

Simple bearings working by gravity load friction are not considered. Sliding and elastic deformable supporting devices neither, being all these types of connections not suitable for the transmission of seismic actions.

0.2 Terminology

In this document the following terms are used.

<i>union</i>	generic linking constraint between two or more members;
<i>connection</i>	local region that includes the union between two or more members;
<i>connector</i>	(usually metallic) linking device interposed between the parts to be connected;
<i>node</i>	local region of convergence between different members;
<i>joint</i>	equipped interface between adjacent members;
<i>(joint) systems</i>	linking practices classified on the basis of the execution technology.

Joints can be classified in three main systems:

<i>typical joint system</i>	dry joints with mechanical connectors generally composed of angles, plates, channel bars, anchors, fasteners, bolts, dowel bars, ..., including joints completed in-situ with mortar for filling or fixing;
<i>emulative joint system</i>	wet joints with rebar splices and cast-in-situ concrete restoring the monolithic continuity proper of cast-in-situ structures and leading usually to "moment-resisting" unions;
<i>mechanical joint system</i>	dry joints with bolted flanges or other steel fittings similar to those used in metallic constructions fixed at the end of the precast member.

0.3 Properties

A connection is composed by three parts: two lateral parts A and C corresponding to the local regions of the adjacent members close to the connector; a central part B constituted by the connector itself with its steel components (see Figure 1).

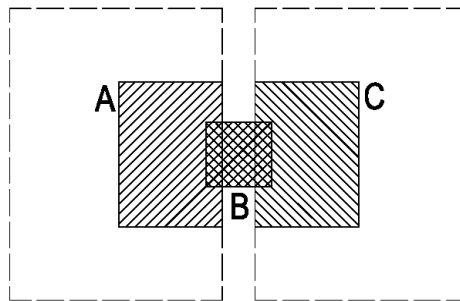

Figure 1. Scheme of connection.

The main parameters which characterize the seismic behaviour of the connection, as measured through monotonic and cyclic tests (see annex A), refer to the six properties of:

-*strength*: maximum value of the force which can be transferred between the parts;

-*ductility*: ultimate plastic deformation* compared to the yielding limit;

-*dissipation*: specific energy dissipated through the load cycles related to the correspondent perfect elastic-plastic cycle;

-*deformation*: ultimate deformation at failure or functional limit;

-*decay*: strength loss through the load cycles compared to the force level;

-*damage*: residual deformation at unloading compared to the maximum displacement and/or details of rupture.

*Instead of the plastic deformation of steel element beyond the yield limit, other physical equivalent non conservative phenomena can be referred to (such as friction).

When the parts A and C have a non-ductile non-dissipative behaviour characterized by a brittle failure, with small displacements, due to the tensile cracking of concrete, a ductile dissipative behaviour of the

connection can be provided by the steel connector B, if correctly designed for a failure involving flexural or tension-compression modes and not shear modes or by other dissipative phenomena like friction. In this case, for a ductile connection, in addition to a ductile connector, the criteria of capacity design shall be applied, under-proportioning the connector with respect to the lateral parts.

Also the geometric compatibility of deformations shall be checked (e.g. against the loss of bearing). Non ductile connections shall be opportunely over-proportioned by capacity design with respect to the resistance of the critical dissipative regions of the structure or proportioned on the base of the action obtained from a structural analysis that doesn't account for any energy dissipation capacity.

The ductility of the connections may contribute or not to the global ductility of the structure depending on their position in the structural assembly and on their relative stiffness.

0.4 Classification

For any single type of connection the strength will be quantified by means of the pertinent calculation formulae. The other behaviour properties listed in 0.4 will be quantified by numerical specific values. When this precise numerical quantification is not possible, because of lack of experimental data or excessive variability of the performances, the type of connection will be classified in qualitative terms corresponding to ranges of values.

For **strength** the following information will be given:

- behaviour models* corresponding to the working mechanisms of the connection;
- failure modes* of the resistant mechanisms;
- calculation formulae* for the evaluation of the ultimate strength for any failure mode;
- any other data* concerning the specific properties of the connection.

Reference is made to the strength obtained from cyclic loading tests.

For **ductility** the following classification will be deduced from the force-displacement diagrams obtained experimentally (see annex A):

- brittle connections* for which failure is reached without relevant plastic deformation;
- over-resisting* for which at the functional deformation limit failure has not been reached;
- ductile connections* for which a relevant plastic deformation has been measured.

In this classification intentional friction mechanism is equalised to plastic deformation. Brittle connections can be used in seismic zones provided they are over-proportioned by capacity design with respect to the critical regions of the overall structure or proportioned with the action deduced from a structural analysis that doesn't account for any energy dissipation capacity.

Furthermore ductile connections are shared out into:

- high ductility* with a displacement ductility ratio of at least 4,5;
- medium ductility* with a displacement ductility ratio of at least 3,0;
- low ductility* with a displacement ductility ratio of at least 1,5.

With ductility ratio lower than 1,5 the connection is classified as brittle.

These definitions refer to the connection itself and in general have not direct relation with the global ductility of the structure. For any single order of connections specific indications are given on this aspect, referring both to ductility and dissipation.

For **dissipation** the following classification will be deduced from the force-displacement diagrams of cyclic tests and related enveloped area histograms (see Annex A):

- non dissipative* connections with specific values of dissipated energy lower than 0,10;
- low dissipation* with specific values of dissipated energy between 0,10 and 0,30;
- medium dissipation* with specific values of dissipated energy between 0,30 and 0,50;
- high dissipation* with specific values of dissipated energy over 0,50;

where the value 1,00 corresponds to the maximum energy dissipated through a perfect elastic-plastic cycle by a massive section of ductile steel under alternate flexure, medium dissipation corresponds to well confined reinforced concrete sections under alternate flexure and high dissipation can be achieved with the use of special dissipative devices.

For **deformation** indications are possibly given about the order of magnitude of the relative displacements of the connection at certain relevant limits such as the first yielding of steel devices, the ultimate failure limit or the maximum allowable deformation referred to its functionality.

Indications about cyclic **decay** and **damage** are given if relevant and when specific experimental information are available.

06 Bibliography

Some references are here listed together with the corresponding abbreviated symbol used in the text.

- EC2* EN 1992-1-1 Eurocode 2: Design of concrete structures – Part 1-1: General rules and rules for Buildings, 2004 CEN

- TS2* TS 1992-2 Technical specification: Design of fastenings for use in concrete – Part 2: Headed studs, 2007 CEN

- TS4* TS 1992-4 Technical specification: Design of fastenings for use in concrete – Part 4: Post-installed fasteners – mechanical systems, 2007 CEN

- EC3* EN 1993-1-1 Eurocode 3: Design of steel structures – Part 1-1 General rules and rules for Buildings, 2005 CEN

- PT8* EN 1993-1-8 Eurocode 3: Design of steel structures – Part 1-8 Design of joints, 2005 CEN

- EC8* EN 1998-1 Design of structures for earthquake resistance – Part 1: General rules, seismic action and rules for buildings, 2004 CEN

- ETS* European Technical Specification of the concerned product

1. FLOOR-TO-FLOOR CONNECTIONS (ORDER 1)

1.1 CAST-IN-SITU TOPPING

1.1.1 General

Figure 1.1.1 shows the detail of a roof made of precast elements interconnected by a concrete topping cast over their upper surface. The concrete topping, with its reinforcing steel mesh, provides a monolithic continuity to the floor that involves also the precast elements if properly connected to it. The diaphragm action for the in plane transmission of the horizontal forces to the bracing vertical elements of the structure can be allotted entirely to the topping. Unless greater dimensions are defined from design, for its structural functions the concrete topping shall have a minimum thickness related also to the maximum aggregate size of the concrete and to overlapped reinforcing steel meshes, such as $t_{\min}=2,4d_g \geq 60$ mm.

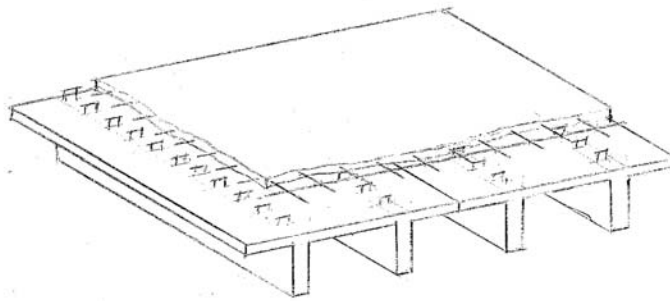

Fig. 1.1.1

1.1.2 Strength

Interface shear strength of the connection between the precast element and the topping under seismic action can be evaluated with equation (6.25) of *EC2* neglecting the friction contribution due to gravity loads.

Transverse vertical shear at the joint between adjacent floor elements is diverted into the topping. For the good behaviour of the connection, proper steel links crossing the interface shall ensure, with adequate anchorages, an effective tension tie between the two parts (see Figure 1.1.2).

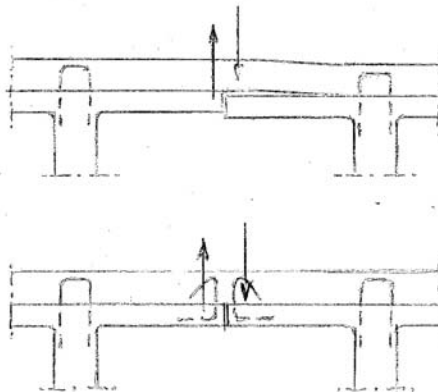

Fig. 1.1.2

1.1.3 Other properties

No specific parameters of seismic behaviour (ductility, dissipation, deformation, decay, damage) have been experimentally measured for this type of indirect connection provided by the cast-in-situ topping that can be calculated like an ordinary reinforced concrete element.

1.2 CAST-IN- SITU JOINTS

1.2.1 General

Figure 1.2.1 shows the floor-to-floor connection made with the concrete filling in of a continuous joint between adjacent elements. It is typical of some precast products like the hollow-core slabs. The joint has a proper shape to ensure, when filled in, the good interlock with the transmission of the vertical transverse shear forces. For the transmission of the horizontal longitudinal shear forces the interface shear strength can be improved providing the adjoining edges with vertical indentations. With reference to the diaphragmatic action, this type of connections ensures to the floor the same performance as a monolithic cast-in-situ floor under condition that a continuous peripheral tie is placed against the opening of the joints. For a good filling up the maximum size of the aggregate of the cast-in-situ concrete shall be limited with reference to the joint width.

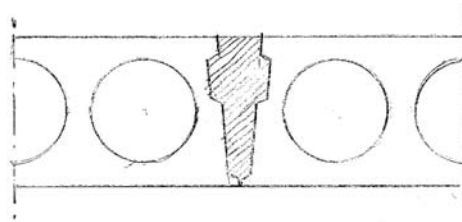

Fig. 1.2.1

Other types of floor-to-floor cast-in-situ connections, possibly provided with spliced tying steel links, are not considered in this document.

1.2.2 Strength

The type of connection of concern is usually intended as a continuous longitudinal hinge. Its strength is ensured following the specifications for the erection of the elements given by the manufacturer.

1.2.3 Other properties

No ductility and dissipation capacities are expected from the concerned type of connections, that are located away from the critical regions of the structure.

1.3 WELDED STEEL CONNECTORS

1.3.1 General

In Figure 1.3.1 two types of floor-to-floor welded connections are represented. The solution (a) is constituted by two steel angles inserted at the edges of the adjacent elements and fixed to them with anchor loops. On the joint lap a bar is placed welded in site to the angles, compensating the erection tolerances. The solution (b) is constituted by two steel plates inserted at the edges of the adjacent elements and fixed to them with anchor loops. Over the joint a middle smaller plate is placed, welded in site to the lateral ones. In both solutions the steel components may be placed within a recess in order to save the upper plane surface of the finishing. In the first solution the angles may be replaced with plates placed inclined so to leave in the joint a V room for the positioning of the middle bar. These kind of connections are used to join ribbed floor elements without topping. They are also used to join special roof elements when placed in contact one to the other.

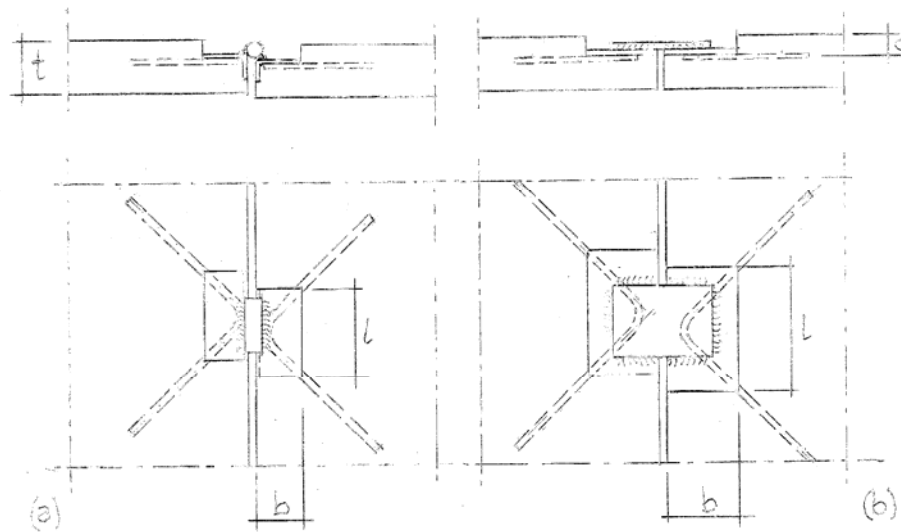

Fig. 1.3.1

These connections are distributed in some local position along the length of the floor elements. They provide the transverse deflection consistency with the uniform distribution of the load between the elements and under seismic conditions they mainly provide the transmission of the diaphragm action with horizontal longitudinal shear forces.

1.3.2 Strength

The following indications about the mechanical behaviour of this type of connections leave out of consideration the transverse vertical shear forces that are related to the distribution of the loads between the elements and refer to a non seismic action. Proper combinations of effects should be added to evaluate the contemporaneity with the seismic action.

1.3.2.1 Behaviour models

With reference to the transmission of the diaphragm action under seismic conditions, the behaviour model is given in Figure 1.3.2 both for the solutions (a) and (b) described in 1.3.1. The longitudinal shear force R shall be mainly transmitted, with no relevant transverse normal forces.

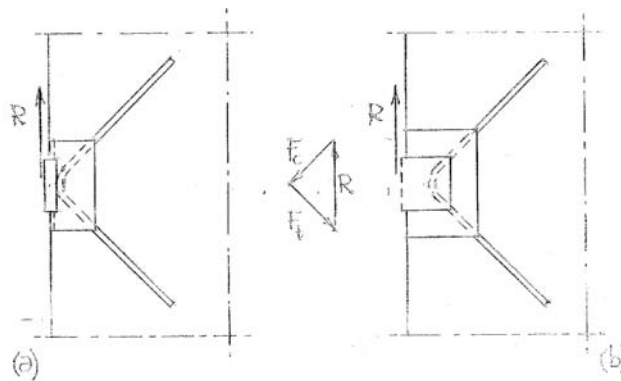

Fig. 1.3.2

1.3.2.2 Failure modes

The principal failure modes are listed hereunder:

- a – rupture of the welding between the angles and the interposed bar or plate;
- b – failure of the interposed plate for solution (b);
- c – failure of the anchor loops for tensile yielding*;
- d – failure of the anchor loops for pull-out*;
- e – spalling of concrete edges due to tensile stresses.

*It is assumed that the anchor loops are fixed to the angles with an adequate welding.

1.3.2.3 Calculation formulae

In expectation of a brittle behaviour of the connection, the action R is evaluated through the analysis of the overall structural system with a behaviour factor properly reduced or through a reliable model of capacity design with respect to the resistance of the critical sections of the structure, using the due overstrength factor γ_R .

° The values $\gamma_R=1,2$ for DCM and $\gamma_R=1,35$ for DCH are recommended by EC8.

a – welding

For the verification of the welding the rules of *PT8* shall be applied.

b – plate
(with t_p thickness and a width of the plate)

$$R_{vR} = 0,67 t_p a f_{yd} / 3 \quad (f_{yd} \text{ design tensile yielding stress of steel})$$

$$(R / R_{vR}) \leq 1$$

c – anchor loop (yielding)
(A_s section of the bar)

$$R_{sR} = 1,41 A_s f_{yd} \quad (f_{yd} \text{ design tensile yielding stress of steel})$$

$$(R / R_{sR}) \leq 1$$

d – pull-out
(ϕ diameter of the bar, l_b anchorage length)

$$R_{bR} = 1,41 \pi \phi l_b f_{bd} \quad f_{bd} = 2,25 f_{ctd} \quad (\text{see 8.4.2 of EC2})$$

$$(R / R_{bR}) \leq 1$$

e – spalling
(for t , b , l and c see Figure 1.3.1)

$$R_{cR} = 2 a h f_{ctd}$$

$$h = 2 c \leq t$$

$$a = b \leq l$$

$$(R / R_{cR}) \leq 1$$

1.3.3 Other properties

No ductility and dissipation capacities are expected from the concerned type of connections, that are located away from the critical regions of the structure.

1.4 BOLTED STEEL CONNECTORS

1.1.1 General

In Figure 1.4.1 a type of floor-to-floor bolted connection is represented. Over the joint a plate is placed, bolted in site to the bushes inserted in the lateral parts and fixed to them with anchor loops. The plate has slotted holes to compensate tolerances and may be placed within a recess in order to save the upper plane surface of the finishing. These kind of connections are used to join ribbed floor elements without topping. They are also used to join special roof elements when placed in contact one to the other.

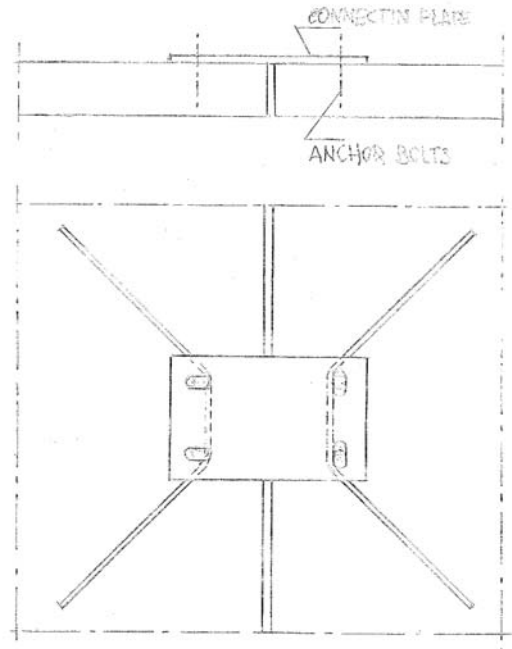

Fig. 1.4.1

These connections are distributed in some local position along the length of the floor elements. They provide the transverse deflection consistency with the uniform distribution of the load between the elements and under seismic conditions they mainly provide the transmission of the diaphragm action with horizontal longitudinal shear forces.

1.4.2 Strength

The following indications about the mechanical behaviour of this type of connections leave out of consideration the transverse vertical shear forces that are related to the distribution of the loads between the elements and refer to a non seismic action. Proper combinations of effects should be added to evaluate the contemporaneity with the seismic action.

1.4.2.1 Behaviour models

With reference to the transmission of the diaphragm action under seismic conditions, the behaviour model is given in Figure 1.4.2. The longitudinal shear force R shall be mainly transmitted, with no relevant transverse normal forces.

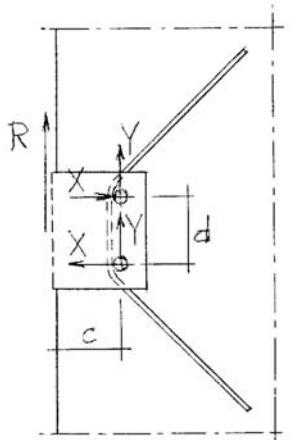

Fig. 1.4.2

1.4.2.2 Failure modes

The principal failure modes are listed hereunder:

- a – shear failure of the anchor bolt;
- b – failure of the interposed plate;
- c – failure of the anchor loops for tensile yielding;
- d – failure of the anchor loops for pull-out;
- e – spalling of concrete edges due to tensile stresses.

1.4.2.3 Calculation formulae

In expectation of a brittle behaviour of the connection, the action R is evaluated through the analysis of the overall structural system with a behaviour factor properly reduced or through a reliable model of capacity design with respect to the resistance of the critical sections of the structure, using the due overstrength factor γ_R° .

With reference to the symbols of Figure 1.4.2 the following effect arises:

$$X = R c / d \quad Y = R / 2 \quad F_d = \sqrt{X^2 + Y^2}$$

[°] The values $\gamma_R=1,2$ for DCM and $\gamma_R=1,35$ for DCH are recommended by EC8.

a – bolt

(with A_b core section of the bolt and f_{tk} its characteristic tensile strength):

$$F_{VRd} = A_b f_{vd} \quad (f_{vd} = 0,7 f_{tk} / \gamma_{M2})^\wedge$$

$$(F_d / F_{VRd}) \leq 1$$

[^] The value $\gamma_{M2}=1,25$ is recommended by EC3 (see also PT8).

b – plate

(with t thickness and a width of the plate)

$$R_{vR} = 0,67 t a f_{yd} / 3 \quad (f_{yd} \text{ design tensile yielding stress of steel})$$

$$(R / R_{vR}) \leq 1$$

c – anchor loop (yielding)

(A_s section of the bar)

$$R_{sR} = 1,41 A_s f_{yd} \quad (f_{yd} \text{ design tensile yielding stress of steel})$$

$$(R / R_{sR}) \leq 1$$

d – pull-out

(ϕ diameter of the bar, l_b anchorage length)

$$R_{bR} = 1,41 \pi \phi l_b f_{bd} \quad f_{bd} = 2,25 f_{ctd} \quad (\text{see 8.4.2 of EC2})$$

$$(R / R_{bR}) \leq 1$$

e – spalling

($f_{ck,cube}$ characteristic compressive cubic strength of concrete, D diameter of the bush, c edge distance of the bush axis, h effective length of the bush)

$$X_{RK} = 2,2 D^\alpha h^\beta \sqrt{(f_{ck,cube} C^3)} \quad \alpha = 0,1 (h / c)^{0,5} \quad \beta = 0,1 (D / c)^{0,2}$$

$$(X / X_{Rd}) \leq 1 \quad (X_{Rd} = X_{RK} / \gamma_C) \quad (h \leq 8 d)$$

where $f_{ck,cube}$ is expressed in N/mm^2 , X and X_{RK} in N and D , h and c in mm .

“ The value $\gamma_C=1,5$ is recommended by EC2 (see also TS4).

1.4.3 Other properties

No ductility and dissipation capacities are expected from the concerned type of connections, that are located away from the critical regions of the structure.

2. FLOOR-TO-BEAM CONNECTIONS (ORDER 2)

For the provisions to protect the concrete edges of the elements against spalling see Chapter 3.

2.1 CAST-IN-SITU JOINTS

2.1.1 General

Figure 2.1.1 shows a typical detail of a cast-in-situ connection between floor elements and a supporting beam. Proper links protrude from the upper side of the beam, overlapped to those protruding from the floor elements. Longitudinal bars are added to improve the mutual anchorage. A concrete casting conglobates the steel links in the joint. This type of connections ensures the transmission of forces without sensible displacements.

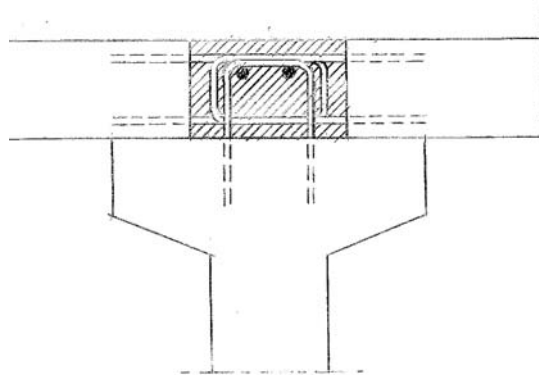

Figure 2.1.1

The detailing of the joint may be differently laid out depending on the type of connected elements and on the arrangement of the connection.

2.1.2 Strength

Interface longitudinal shear strength of the connection between the precast beam and the cast-in-situ joint under seismic action can be evaluated with equation (6.25) of *EC2* neglecting the friction contribution due to gravity loads. Horizontal transverse shear forces between the same parts can be attributed to the shear strength of the steel links protruding from the beam. The link between the floor elements and the cast-in-situ joint can be designed following the rules of *EC2*.

2.1.3 Other properties

No specific parameters of seismic behaviour (ductility, dissipation, deformation, decay, damage) have been experimentally measured for this type of connection. If designed to transfer transverse moments (in addition to forces), the connection can be assumed as energy dissipating when the conditions of Clause 5.11.2.1.3 of *EC8* are met.

For the transmission of longitudinal shear no ductility and dissipation capacities are expected from the concerned type of connections that are located away from the critical sections of the structure.

2.2 SUPPORTS WITH STEEL ANGLES

2.2.1 General

Figure 2.2.1 shows the end connection of a rib of a floor element to a supporting beam. Steel angles are used, applied at one or both sides of the rib and fixed by means of a passing dowel to the rib and by means of anchor bolts (fasteners) to the beam. At the bottom of the rib a U-shape steel sheet can be inserted with a passing pipe welded to it.

The steel angles have a minimum size due to the geometry of the rib with its lower reinforcement and to the work space for the tightening of the anchor bolts. This leads to minimum sides of about 100 mm. If commercial profiles (hot rolled angles) are used with their minimum thickness, at least an angle L100x10 would be chosen, which is very stiff and over-resistant with respect to the expected actions. To allow plastic deformations under cyclic loading, weakened angles can be used, cold formed from thinner steel sheets (e.g. $t=5$ mm) with a rounded corner.

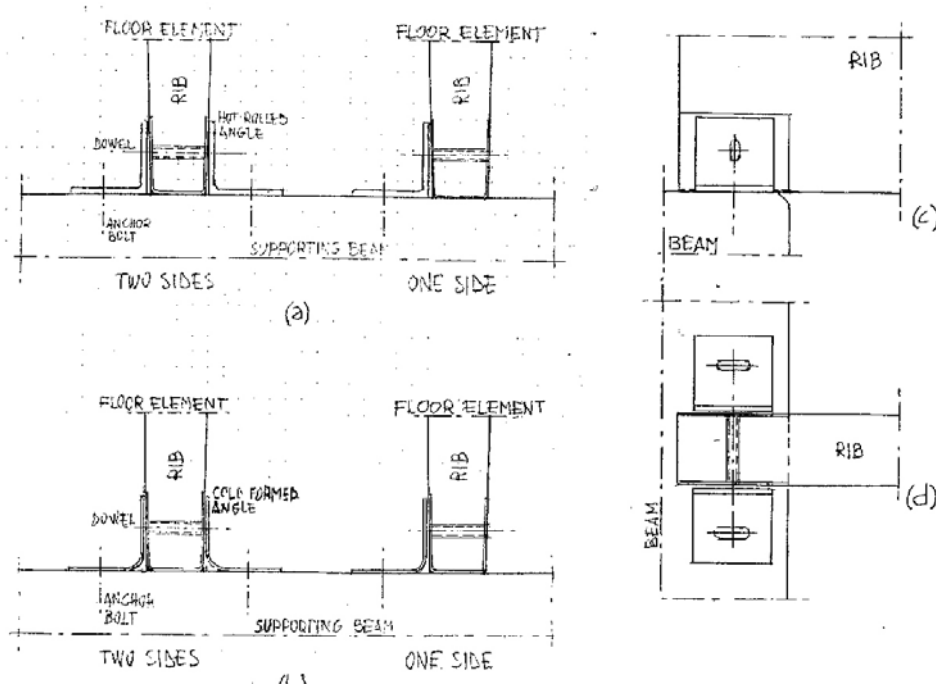

Figure 2.2.1

In the steel angles the holes for dowel and bolts should be slotted in orthogonal directions in order to compensate tolerances. This requires the addition of proper knurled plates to ensure grip in the direction of the holes.

In the overall model for structural analysis this type of connection can be simulated by spherical hinges.

The behaviour in the horizontal transverse direction (see Fig. 2.2.5) has not been tested.

2.2.2 Strength

The following indications about the mechanical behaviour of this type of connection leaves out of consideration the friction that sets up between the parts due to the weight of the supported element. In fact in seismic conditions, under the contemporary horizontal and vertical shakes, the connection shall work instantly also in absence of weight.

With this premise it has to be pointed out that in the longitudinal direction of the rib the constraint given by a steel angle fixed with one bolt to the beam is hypostatic. Only after a finite small rotation the edge of the steel angle gets in contact with the rib adding, in combination with the tensioned dowel, a rotational constraint to the steel angle for a full isostatic connection of the two parts (see Fig. 2.2.2).

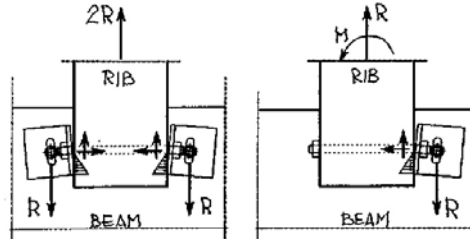

Fig. 2.2.2

2.2.2.1 Behaviour models

Figure 2.2.3 shows the details in plan of the resisting mechanism for an action applied in the longitudinal direction of the rib, both for a two side and an one side connection. The flow of the force R from the rib to the fastener fixed to the beam goes through the intervention of a couple of transverse forces H with an arm z that is related to the dimension $l/2$ of the steel angle. For the one side connection the eccentricity of the two forces R leads to a moment M which effects are compensated by the global system of the opposite connections. These effects are neglected in the following. The main difference between the two solutions of Figure 2.2.3 is the bearing pressure of the pipe containing the dowel on the surrounding concrete: constantly distributed for the two sides connection, variable for the one side connection.

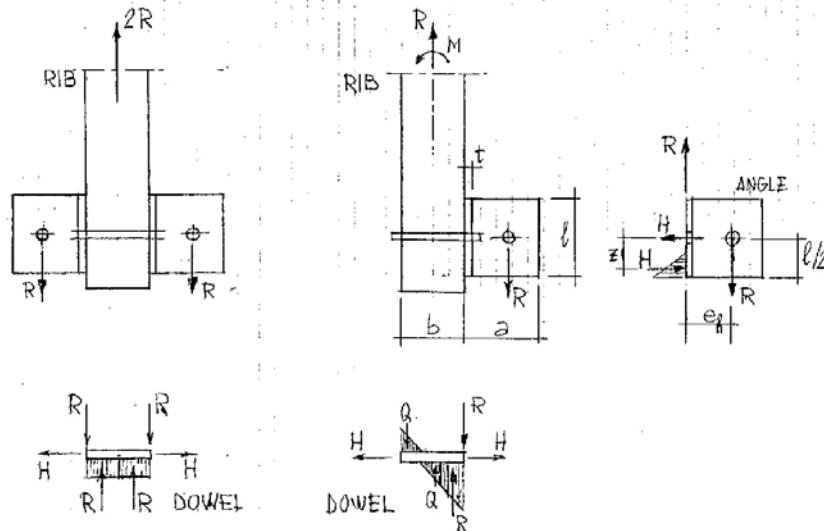

Fig. 2.2.3

Figure 2.2.4 shows the details in elevation of the resisting mechanism for the same longitudinal action. The eccentricity e_y of the two forces R is compensated by a couple of vertical forces V with an arm z that is related to the dimension $l/2$ of the steel angle. This couple carries a tensile “pull-out” action to the fastener and a pressure to the concrete.

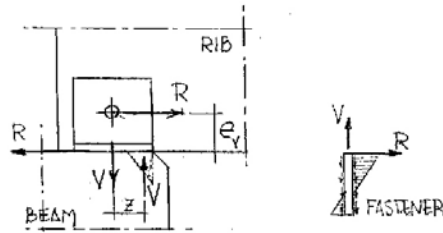

Fig. 2.2.4

In the horizontal transverse direction the force F is transmitted through a direct pressure between the rib and the steel angle in one sense, or through a flexure of the flange of the steel angle indirectly carried by the dowel in tension in the other sense (see Fig. 2.2.5). In the two side solution the two mechanisms are combined together, the first one being expected to be the major because of its greater stiffness. Generally the one side connection is placed in the opposite sides of the two ribs of a floor element and in this way the global force is mainly carried by the steel angle in compression.

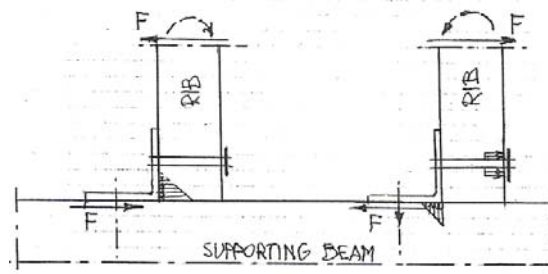

Fig. 2.2.5

2.2.2.2 Failure modes

The principal failure modes for longitudinal action are listed hereunder:

- a – rupture of the external section of the dowel subjected to shear and tension;
- b – local plastic crushing of the steel angle around the holes due to bearing stresses;
- c – breaking of the anchor bolt subjected to shear and tension;
- d – spalling of the concrete edge of the rib due to tensile stresses;
- e – spalling of the concrete edge of the beam due to tensile stresses.

For ordinary proportioning the failure of the steel angle subjected to twisting action is not expected.

2.2.2.3 Calculation formulae

With reference to the symbols of Figures 2.2.3 and 2.2.4, for the action of a given force R evaluated by capacity design with respect to the resistance of the critical sections of the structure using the due overstrength factor γ_R° , the following effects arise:

$$M = R (e_h + b/2)$$

$$H = R e_h / z \quad \text{with } z \approx \ell / 3$$

$$V = R e_v / z \quad \text{with } z \approx \ell / 3$$

^o The values $\gamma_R=1,2$ for DCM and $\gamma_R=1,35$ for DCH are recommended by EC8.

a – dowel

(with A_b core section of the threaded part of the dowel and f_{tk} its characteristic tensile strength):

$$R_{vRd} = A_b f_{vd} \quad H_{Rd} = 0,9 A_b f_{td} \quad (f_{vd} = 0,7 f_{tk} / \gamma_{M2} \quad \text{and} \quad f_{td} = f_{tk} / \gamma_{M2})^\wedge$$

$$(0,71 H / H_{Rd}) + (R / R_{vRd}) \leq 1 \quad \text{and} \quad H / H_{Rd} \leq 1$$

b – steel angle

(with t thickness of the flange, ϕ diameter of the bolt, e edge distance of the bolt axis and f_{tk} characteristic tensile strength of the steel):

$$R_{bRd} = 2,5 t \phi f_{td} \quad \text{for round holes} \quad (f_{td} = f_{tk} / \gamma_{M2})^\wedge$$

$$R_{bRd} = 1,5 t \phi f_{td} \quad \text{for slotted holes perpendicular to the action}$$

$$(R / R_{bRd}) \leq 1 \quad (\text{with } \ell/2 \geq 2,5\phi \text{ and } e \geq 2,0\phi)$$

[^] The value $\gamma_{M2}=1,25$ is recommended by EC3 (see also PT8).

c – anchor bolt

(R_R minimum shear resistance and V_R minimum tensile resistance of the anchor bolt declared by the producer)

$$(R / R_R)^2 + (V / V_R)^2 \leq 1$$

d – rib edge

($f_{ck,cube}$ characteristic compressive cubic strength of concrete, d diameter of the pipe, c edge distance of the dowel axis)

$$R_{Rk} = 1,4 k d^\alpha h^\beta \sqrt{(f_{ck,cube} C^3)} \psi_{re} \quad \alpha = 0,1 (h / c)^{0,5} \quad \beta = 0,1 (d / c)^{0,2}$$

$$k = (s h) / (4,5 c^2) \quad s = 1,5 c + e_v \leq 3,0 c$$

$$h = b / 2 \leq 1,5 c \quad \text{for two sides angles} \quad h = b / 3 \leq 1,5 c \quad \text{for one side angle}$$

$$(R / R_{Rd}) \leq 1 \quad (R_{Rd} = R_{Rk} / \gamma_C)'' \quad (h \leq 8 d)$$

where $f_{ck,cube}$ is expressed in N/mm², R and R_{Rk} in N and d , h , c and e_v in mm and $\psi_{re}=1,4$ in presence of edge reinforcement as specified in 2.2.2.4, or $\psi_{re}=1,0$ in all other cases.

e – beam edge

($f_{ck,cube}$ characteristic compressive cubic strength of concrete, ϕ diameter of the fasteners,
 c edge distance of the fastener axis, $h=8\phi$ effective length of the fastener)

$$R_{Rk} = 1,6 k \phi^\alpha h^\beta \sqrt{(f_{ck,cube} c^3)} \psi_{re} \quad \alpha = 0,1 (h / c)^{0,5} \quad \beta = 0,1 (d / c)^{0,2}$$

$$(R / R_{Rd}) \leq 1 \quad (R_{Rd} = R_{Rk} / \gamma_C)$$

where $f_{ck,cube}$ is expressed in N/mm², R and R_{Rk} in N and d , h , ϕ and c in mm and $\psi_{re}=1,4$ in presence of edge reinforcement as specified in 2.2.2.4, or $\psi_{re}=1,0$ in all other cases.

“ The value $\gamma_C=1,5$ is recommended by EC2 (see also TS4).

2.2.2.4 Any other data

Failure modes d and e related to a tensile cracking of the concrete edge correspond in general to the weakest mechanisms. Their strength depends mainly from the edge distance of the dowel or bolt, from the properties of the concrete and from the reinforcement detailing.

In the ribs of a floor element the ordinary longitudinal reinforcement made of bars of large diameter does not prevent the concrete spalling also if these bars are well anchored by hooks bended at 135°: in fact the bars enter upon effect only after the cracking of concrete, but at this point the support can be jeopardized. In order to control the crack opening and prevent the failure by spalling, an effective edge reinforcement shall be added made of small diameter U-shape horizontal links closely distributed along the lower part of the beam. These horizontal links are particularly important for small c/d values as they restrain the dowels after the cracking of concrete. They shall be distributed over a height e_v+c from the bottom with a spacing not greater than 50 mm and dimensioned for a design resistance equal to the expected action.

To prevent the crack opening and the failure by spalling of the beam edge in case of its local cracking at the floor rib supports, a closely spaced distribution of upper horizontal stirrups or mesh shall be provided with a spacing $s \leq 1,5c \leq 100$ mm and an included longitudinal bar of diameter $\geq 0,12s$ along the corner.

2.2.3 Ductility

In testing the failure limit of the steel connectors has never been reached showing a **over-resisting behaviour**. Moreover the monotonic force-displacement diagram appears affected by different contemporary contributions (settlements, friction, elastic and plastic warping deformation and large shape modifications) that don't allow to locate a well defined yielding limit. By consequence ductility could not be quantified.

To be noted that during testing the load has been applied in such a way to prevent the edge spalling of the concrete rib in tension. Because of possible early failures due to edge spillings, in the real situation on the construction the actual behaviour of the connection could be **brittle**.

2.2.4 Dissipation

Cyclic tests show that the sum of the different contributions leads to a **low dissipation** capacity, sensibly higher for the “weakened” thin cold-formed angles than for the “strong” hot-rolled angles.

Anyway, due to their position in the structural assembly and to their high stiffness in comparison to the column flexibility, no ductility and dissipation is expected from this type of connections.

2.2.5 Deformation

The functional deformation limit has been assumed at ± 24 mm being the total longitudinal drift of about 50 mm the maximum compatible with a no support loss requirement for ordinary proportionings.

2.2.6 Decay

Cyclic tests show that at the functional deformation limit no relevant strength decay displays after the three cycles.

2.2.7 Damage

At the end of the monotonic and cyclic tests taken up to the functional deformation limit large residual deformations remain as a result of the different non conservative effects. Plastic warping deformations of the steel angles are much more evident for the “weakened” thin cold-formed angles than for the “strong” hot-rolled angles.

2.3 SUPPORTS WITH STEEL SHOES

2.3.1 General

Figure 2.3.1 shows the end connection of a rib of a floor element to the supporting beam. A steel shoe is used, made of a lower horizontal plate with two vertical flanges welded to it. The shoe is placed under the rib, fixed to it with a passing dowel and to the beam with two anchor bolts (fasteners). At the bottom of the rib a U-shape steel sheet can be inserted with a passing pipe welded to it.

In the steel shoe the holes for dowel and bolts should be slotted in orthogonal directions in order to compensate tolerances. This requires the addition of proper knurled plates to ensure grip in the direction of the holes.

In the overall model for structural analysis this type of connection can be simulated by spherical hinges.

The behaviour in the horizontal transverse direction (see Fig. 2.3.4) has not been tested.

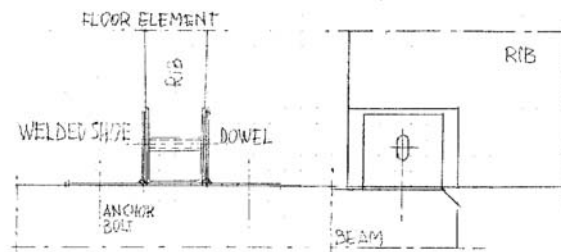

Figure 2.3.1

2.3.2 Strength

The following indications about the mechanical behaviour of this type of connection leaves out of consideration the friction that sets up between the parts due to the weight of the supported element. In fact in seismic conditions, under the contemporary horizontal and vertical shakes, the connection shall work instantly also in absence of weight.

In the longitudinal direction of the rib the shoe gives an isostatic constraint activated without sensible initial settlements.

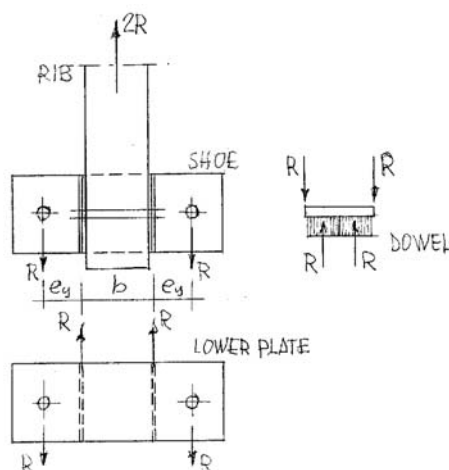

Fig. 2.3.2

2.3.2.1 Behaviour models

Figure 2.3.2 shows the details in plan of the resisting mechanism for an action applied in the longitudinal direction of the rib. The flow of the forces R from the rib to the fasteners fixed to the beam goes through a plane stress distribution in the lower plate of the shoe.

The bearing pressure of the pipe containing the dowel on the surrounding concrete is constantly distributed along the width of the rib.

Figure 2.3.3 shows the details in elevation of the resisting mechanism for the same longitudinal action. The eccentricity e_y of the two forces R is compensated by a couple of vertical forces V with an arm z that is related to the dimension $l/2$ of the steel angle. This couple carries a tensile "pull-out" action to the fastener and a pressure to the concrete corner.

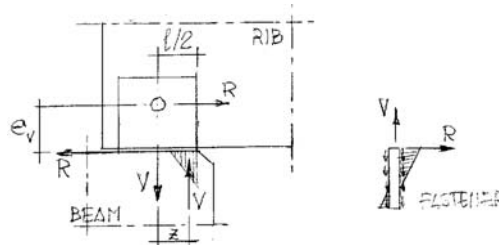

Figure 2.3.3

In the horizontal transverse direction the force F is transmitted through a direct pressure between the rib and one flange combined with a flexure of the opposite flange indirectly carried by the dowel in tension (see Fig. 2.3.4), where the first effect is expected to be the major because of its greater stiffness. At the base the force is equally distributed on the two fasteners by the in plane stiffness of the lower plate.

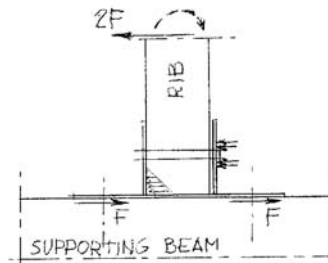

Figure 2.3.4

2.3.2.2 Failure modes

The principal failure modes for longitudinal action are listed hereunder:

- a – rupture of the external section of the dowel subjected to shear;
- b – local plastic crushing of the steel flanges or plate around the holes due to bearing stresses;
- c – breaking of the anchor bolts subjected to shear and tension;
- d – spalling of the concrete edge of the rib due to tensile stresses;
- e – spalling of the concrete edge of the beam due to tensile stresses.

For ordinary proportioning the failure of the steel shoe subjected to in plane and twisting action is not expected.

2.3.2.3 Calculation formulae

With reference to the symbols of Figure 2.3.3, for the action of a given force R evaluated by capacity design with respect to the resistance of the critical sections of the structure using the due overstrength factor γ_R° , the following effect arises:

$$V = R e_v / z \quad \text{with } z \approx \ell / 3$$

° The values $\gamma_R=1,2$ for DCM and $\gamma_R=1,35$ for DCH are recommended by EC8.

a – dowel

(with A_b core section of the threaded part of the dowel and f_{tk} its characteristic tensile strength):

$$R_{vRd} = A_b f_{vd} \quad (f_{vd} = 0,7 f_{tk} / \gamma_{M2})^\wedge$$

$$(R / R_{vRd}) \leq 1$$

b – steel shoe (flanges and lower plate)

(with t thickness of the flanges or plate, ϕ diameter of the bolt, e edge distance of the bolt axis and f_{tk} characteristic tensile strength of the steel):

$$R_{bRd} = 2,5 t \phi f_{td} \quad \text{for round holes} \quad (f_{td} = f_{tk} / \gamma_{M2})^\wedge$$

$$R_{bRd} = 1,5 t \phi f_{td} \quad \text{for slotted holes perpendicular to the action}$$

$$(R / R_{bRd}) \leq 1 \quad (\text{with } \ell/2 \geq 2,5\phi \text{ and } e \geq 2,0\phi)$$

^\wedge The value $\gamma_{M2}=1,25$ is recommended by EC3 (see also PT8).

c – anchor bolt

(R_R minimum shear resistance and V_R minimum tensile resistance of the anchor bolt declared by the producer)

$$(R / R_R)^2 + (V / V_R)^2 \leq 1$$

d – rib edge

($f_{ck,cube}$ characteristic compressive cubic strength of concrete, d diameter of the pipe, c edge distance of the dowel axis)

$$R_{Rk} = 1,4 k d^\alpha h^\beta \sqrt{(f_{ck,cube} C^3)} \psi_{re} \quad \alpha = 0,1 (h / c)^{0,5} \quad \beta = 0,1 (d / c)^{0,2}$$

$$k = (s h) / (4,5 c^2) \quad s = 1,5 c + e_v \leq 3,0 c$$

$$h = b / 2 \leq 1,5 c \quad \text{for two sides angles} \quad h = b / 3 \leq 1,5 c \quad \text{for one side angle}$$

$$(R / R_{Rd}) \leq 1 \quad (R_{Rd} = R_{Rk} / \gamma_C)'' \quad (h \leq 8 d)$$

where $f_{ck,cube}$ is expressed in N/mm², R and R_{Rk} in N and d , h , c and e_v in mm and $\psi_{re}=1,4$ in presence of edge reinforcement as specified in 2.3.2.4, or $\psi_{re}=1,0$ in all other cases.

e – beam edge

($f_{ck,cube}$ characteristic compressive cubic strength of concrete, ϕ diameter of the fasteners, c edge distance of the fastener axis, $h=8\phi$ effective length of the fastener)

$$R_{Rk} = 1,6 k \phi^\alpha h^\beta \sqrt{(f_{ck,cube} c^3)} \psi_{re} \quad \alpha = 0,1 (h / c)^{0,5} \quad \beta = 0,1 (d / c)^{0,2}$$

$$(R / R_{Rd}) \leq 1 \quad (R_{Rd} = R_{Rk} / \gamma_C)$$

where $f_{ck,cube}$ is expressed in N/mm², R and R_{Rk} in N and d , h , ϕ and c in mm and $\psi_{re}=1,4$ in presence of edge reinforcement as specified in 2.3.2.4, or $\psi_{re}=1,0$ in all other cases.

“ The value $\gamma_C=1,5$ is recommended by EC2 (see also TS4).

2.3.2.4 Any other data

Failure modes d and e related to a tensile cracking of the concrete edge correspond in general to the weakest mechanisms. Their strength depends mainly from the edge distance of the dowel or bolt, from the properties of the concrete and from the reinforcement detailing.

In the ribs of a floor element the ordinary longitudinal reinforcement made of bars of large diameter does not prevent the concrete spalling also if these bars are well anchored by hooks bended at 135°: in fact the bars enter upon effect only after the cracking of concrete, but at this point the support can be jeopardized. In order to control the crack opening and prevent the failure by spalling, an effective edge reinforcement shall be added made of small diameter U-shape horizontal links closely distributed along the lower part of the beam. These horizontal links are particularly important for small c/d values as they restrain the dowels after the cracking of concrete. They shall be distributed over a height e_v+c from the bottom with a spacing not greater than 50 mm and dimensioned for a design resistance equal to the expected action.

To prevent the crack opening and the failure by spalling of the beam edge in case of its local cracking at the floor rib supports, a closely spaced distribution of upper horizontal stirrups or mesh shall be provided with a spacing $s \leq 1,5c \leq 100$ mm and an included longitudinal bar of diameter $\geq 0,12s$ along the corner.

2.3.3 Ductility

In testing the failure limit of the steel connectors has never been reached showing a **over-resisting behaviour**. Moreover the monotonic force-displacement diagram doesn't show a well defined yielding limit. By consequence ductility could not be quantified.

To be noted that during testing the load has been applied in such a way to prevent the edge spalling of the concrete rib in tension. Because of possible early failures due to edge spillings, in the real situation on the construction the actual behaviour of the connection could be **brittle**.

2.3.4 Dissipation

Cyclic tests show a **low dissipation** capacity. Anyway, due to their position in the structural assembly and to their high stiffness in comparison to the column flexibility, no ductility and dissipation is expected from this type of connections.

2.3.5 Deformation

The functional deformation limit has been assumed at ± 24 mm being the total longitudinal drift of about 50 mm the maximum compatible with a no support loss requirement for ordinary proportionings.

2.3.6 Decay

Cyclic tests show that at the functional deformation limit no relevant strength decay displays after the three cycles.

2.3.7 Damage

At the end of the monotonic and cyclic test taken up to the functional deformation limit, large residual deformations remain as a result of different non conservative effects. Residual plastic warping deformations of the steel shoe are evident.

2.4 WELDED SUPPORTS

2.4.1 General

Figure 2.4.1 shows the welded connection of the rib of a floor element to a supporting beam. A U-shape steel sheet is inserted at the bottom of the rib, anchored to it with proper fasteners. An L-shape steel sheet is inserted to the edge of the beam, anchored to it with proper fasteners. Weldings are made in site to connect the two parts. The number (one or two) of the weldings is determined by the possibility of access of the welder from the sides of the rib of the floor element.

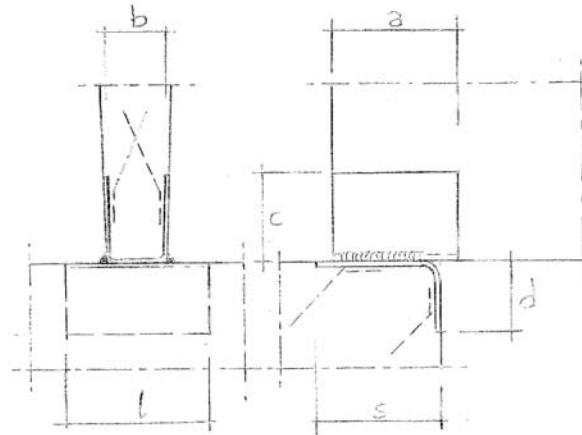

Figure 2.4.1

The thickness of the steel sheets shall be proportioned with reference to the throat thickness of the welding. Adequate anchor loops shall ensure their full anchorage to the concrete parts.

2.4.2 Strength

The following indications about the mechanical behaviour of this type of connection leaves out of consideration the friction that sets up between the parts due to the weight of the supported element. In fact in seismic conditions, under the contemporary horizontal and vertical shakes, the connection shall work instantly also in absence of weight.

2.4.2.1 Behaviour models

Figure 2.4.2 shows the details in plan of the connection with indicated the two components R and F of the horizontal action expected in seismic conditions. In structural analysis the connection is assumed to be a spherical hinge. Actually unintended small moments can be transmitted. They can be neglected in the design of the connected elements (beam and floor). They have effects on the connection itself, additional to those considered below, that can be taken over by its ductility resources.

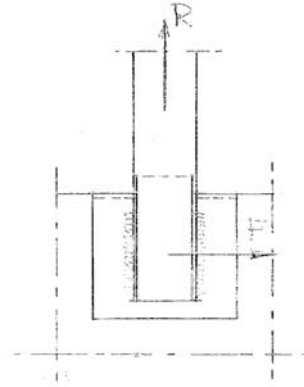

Fig. 2.4.2

2.4.2.2 Failure modes

The principal failure modes are listed hereunder.

- a – rupture of the welding;
- b – failure of the fastenings anchored in the rib of the floor element;
- c – failure of the fastenings anchored in the beam;
- d – spalling of the concrete edge of the rib due to tensile stresses;
- e – spalling of the concrete edge of the beam due to tensile stresses.

2.4.2.3 Calculation formulae

With reference to the symbols of Figure 2.4.1, for the action of a given force R evaluated by capacity design with respect to the resistance of the critical sections of the structure using the due overstrength factor γ_R° , the following verifications apply (with f_{ctd} design value of the tensile strength of concrete):

^o The values $\gamma_R=1,2$ for DCM and $\gamma_R=1,35$ for DCH are recommended by EC8.

a – welding

For the verification of the welding the rules of *PT8* shall be applied.

b/c – fastenings

A proper design of the anchoring system shall be made referring to the specific arrangement of the fasteners.

d – rib edge

$$R_{rR} = 0,25 b h f_{ctd}$$

$$h = a + c \leq 2a$$

(for a , b and c see Figure 2.4.1)

e – beam edge

$$R_{bR} = 0,25 t h f_{ctd}$$

$$h = l + s \leq 2s \quad t = d + s \leq 2s \quad (\text{for } l, s, d \text{ and } t \text{ see Figure 2.4.1})$$

The resistance of the steel sheets is assumed to be verified if their thickness is not less than the throat thickness of the welding.

2.4.2.4 Any other data

Failure modes *d* and *e* related to a tensile cracking of the concrete edge correspond in general to the weakest mechanisms. Their strength depends mainly from the edge distance of the dowel or bolt, from the properties of the concrete and from the reinforcement detailing.

In the ribs of a floor element the ordinary longitudinal reinforcement made of bars of large diameter does not prevent the concrete spalling also if these bars are well anchored by hooks bended at 135°: in fact the bars enter upon effect only after the cracking of concrete, but at this point the support is jeopardized. In order to control the crack opening and prevent spalling, an effective edge reinforcement can be added made of small diameter U-shape horizontal links closely distributed along the lower part of the rib edge.

The use of steel fibre reinforced concrete at the end of the rib can be as well effective on controlling the crack opening.

The presence of pre-tensioned adherent wires or strands may contribute to improve the local behaviour reducing the tensile stresses in the concrete.

2.4.3 Other properties

No specific parameters of seismic behaviour (ductility, dissipation, deformation, decay, damage) have been experimentally measured for this type of connection, for which no ductility and dissipation capacities are expected.

2.5 HYBRID CONNECTIONS

2.5.1 General

Figure 2.5.1 shows the end connections of floor ribbed elements to a supporting beam. The term “hybrid” refers to the connection arrangement made at the upper part with additional bars and cast-in-situ concrete proper of an emulative joint and at the lower part with mechanical steel devices proper of a typical joint. The upper cast-in-situ slab is connected to the precast elements by the protruding stirrups that resist the longitudinal shear transmitted through the interface. The lower connection can be made with one of the solutions described in Clauses 2.2, 2.3 and 2.4. In what follows the solution of welded support described in Figure 2.4.1 is referred to.

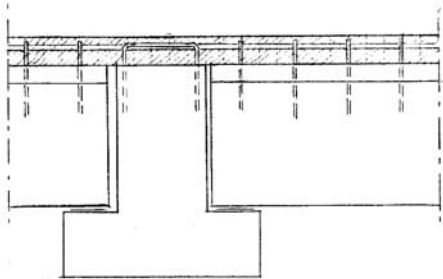

Figure 2.5.1

2.5.2 Strength

This type of connection, after the hardening of the cast-in-situ concrete topping, provides a moment resisting support between the parts, with a dissymmetrical behaviour for positive and negative moments. The loads applied after the hardening of the topping take their action on this moment resisting connection. The self weight of the floor elements, included the concrete topping, acts on a simple hinged support arrangement.

2.5.2.1 Behaviour models

In both stages of hinged and fixed support, the shear force coming from the floor element is assumed to go entirely on the flange standing out from the beam web. The local detailing and design calculation of flange and web shall be made following the provisions of EC2.

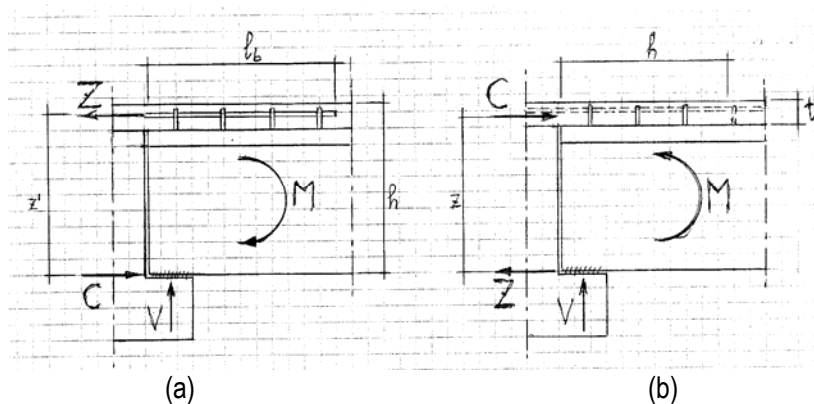

Figure 2.5.2

Figures 2.5.2a-b show the resisting mechanisms respectively for negative and positive moments. In the first mechanism the tensile force Z acts in the longitudinal bars added in the cast-in-situ topping and the compressive force $C (=Z)$ comes from the bottom weldings with a lever arm z' . In the second mechanism the compressive force C acts in the cast-in-situ topping and the tensile force $Z (=C)$ comes from the bottom weldings with a lever arm z .

2.5.2.2 Failure modes

For a negative moment the principal failure modes are listed hereunder.

- a - flexural failure of the connection referred to the yielding of the longitudinal upper bars;
- b – bond failure of the anchorage of the upper bars;
- c – longitudinal shear failure at the interface between precast element and cast-in-situ slab;
- d – failure of the bottom connection between the rib and the supporting flange.

For a positive moment the principal failure modes are listed hereunder.

- e – flexural failure of the connection referred to the rupture of the bottom connection;
- f – longitudinal shear failure of the interface between precast element and cast-in-situ slab;

2.5.2.3 Calculation formulae

For a negative moment (see Figure 2.5.2a) the ultimate resisting value (with A_{st} total sectional area of the longitudinal upper bars) can be calculated by:

$$M_{Rd} = A_s f_{yd} z' \quad f_{yd} \text{ design tensile yielding stress of steel}$$

- a – flexure

$$M_{Rd} \geq M_{Ed}$$

where M_{Ed} is the design value coming from the structural analysis and for seismic action condition could be calculated by capacity design with a proper overstrength factor γ_R .

- b – bar anchorage

(l_b anchorage length of a bar in the upper slab, A_s its sectional area, u its perimeter, f_{ctd} design tensile strength of the cast-in-situ concrete, f_{yk} characteristic yield strength of steel)

$$l_b u f_{bd} \geq \gamma_R A_s f_{ym}$$

where

$$f_{bd} = 2,25 f_{ctd} \quad \text{ultimate bond strength (see 8.4.2 of EC2)}$$

$$f_{ym} = 1,08 f_{yk} \quad \text{mean yielding stress of the steel}$$

- c – longitudinal shear

(A_{ss} total sectional area of the protruding stirrups available in the end segment long h of the element)

$$A_{ss} f_{yd} \geq \gamma_R A_{st} f_{ym}$$

d – bottom connection

verifications *a-b-c* of point 2.4.2.3 shall be applied referring to an acting force $R = \gamma_R A_{st} f_{ym}$.

For a positive moment (see Figure 2.5.2b) the resisting value can be calculated by

$$M_{Rd} = R_R z$$

where R_R is the minimum resistance of the bottom connection calculated from all the failure modes covered by 2.4.2.3 and $z \approx h-t/2$.

e – flexure

$$M_{Rd} \geq M_{Ed}$$

where M_{Ed} is the design value coming from the structural analysis and for seismic action condition could be calculated by capacity design with a proper overstrength factor γ_R .

f – longitudinal shear

(A_{ss} total sectional area of the protruding stirrups available in the end segment long h of the element)

$$A_{ss} f_{yd} \geq \gamma_R R_R$$

2.5.2.4 Any other data

The overstrength factor γ_R of the formulae given in 2.5.2.3 shall be properly quantified evaluating the role of the connection behaviour on the seismic response of the structure. If no relevant role is played by the connection of concern $\gamma_R=1,0$ can be assumed. Otherwise the values $\gamma_R=1,2$ for DCM and $\gamma_R=1,35$ for DCH shall be assumed as recommended by EC8.

2.5.3 Other properties

No specific parameters of seismic behaviour (ductility, dissipation, deformation, decay, damage) have been experimentally measured for this type of connection, for which no ductility and dissipation capacities are normally expected. A general indication can be given about the flexural failure modes *a* and *e*, the first one related to negative moments being expected to be ductile, the second one related to positive moments being expected to be brittle.

3 BEAM-TO-COLUMN CONNECTIONS (ORDER 3)

In order to protect the concrete edges of column and beam against spalling, due to the concentration of stresses under the flexural deformation of beam and column (see Figures 3.0a-b), proper provisions shall be adopted. These provisions shall prevent the application of strong pressures on a strip of the bearing area close to the corner. The width a of this strip should correspond to the concrete cover to the confining reinforcement and indicatively should be not lesser than 20 mm.

Figure 3.0c shows a first possible solution with a chamfered edge. Figure 3.0d shows a second possible solution with the edge protected by a cold formed steel angle properly anchored to the column. Figure 3.0e shows a third possible solution with an interposed deformable rubber pad. Figure 3.0f finally shows a fourth possible solution with an interposed rigid steel plate.

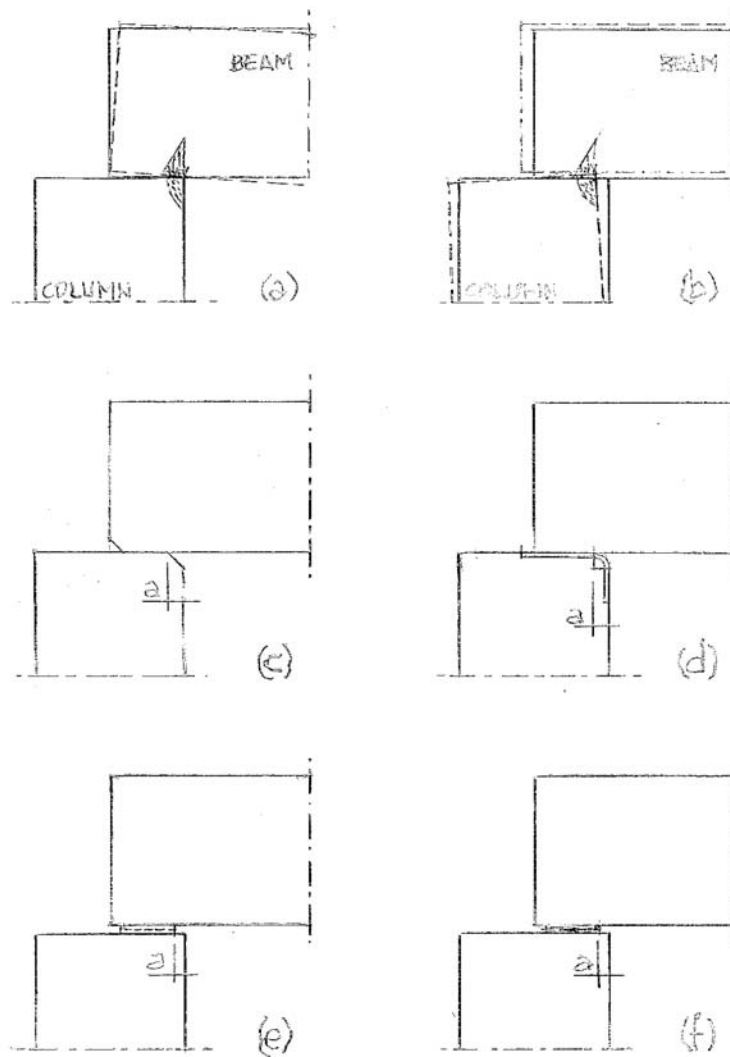

Figure 3.0

3.1 CAST-IN-SITU CONNECTIONS

3.1.1 General

Figure 3.1.1 shows typical cast-in-situ connections between beams and columns placed in different positions. In the case (a) the connection is placed on the top of the column, from which the longitudinal bars protrude into the joint and overlap with those protruding from the beams. A concrete casting conglobates the overlapped bars in the joint. The size of the joint shall provide the room necessary for the required overlapping lengths. This type of connection ensures the transmission of forces and moments among the elements without sensible displacements. It falls within the possible critical regions of the resisting frame under seismic actions.

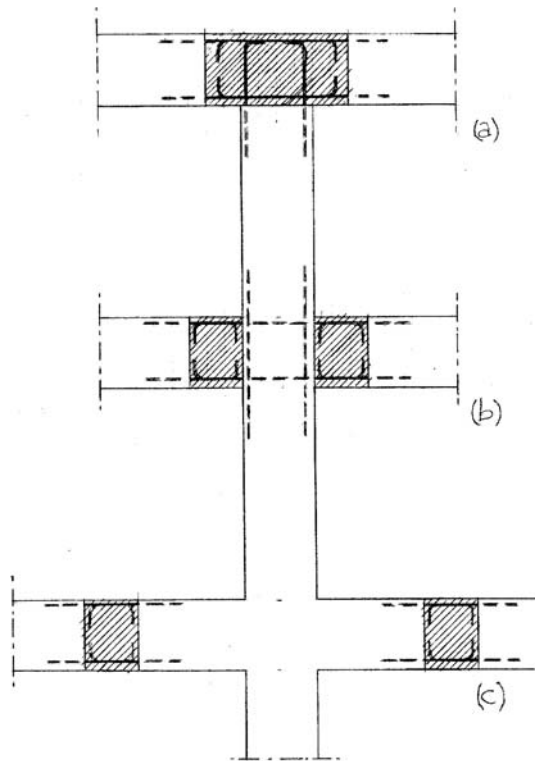

Figure 3.1.1

In the case (b) the connection is placed at an intermediate storey and is divided into two separate parts, one at each side of the column. Proper bars protrude from the column into the lateral joints and overlap for the necessary length with those protruding from the beams. In this way the continuity of the column with its reinforcing bars is saved. Connections of this type ensure the transmission of forces and moments among the elements without sensible displacements. They fall within the possible critical regions of the resisting frame under seismic actions.

In order to move the connections out of the possible critical regions of the beams the solution (c) may be adopted. In all the three cases described above proper temporary props shall be provided to the beams in the transient situations of the execution stages.

The connection can be moved into the size of the column as shown in Figure 3.1.2a. Within the depth of the floor in transient situation the continuity of the column is given only by the passing longitudinal bars. The necessity of temporary props during erection can be avoided if the continuity bars are moved to

an inner position so to leave room for the sitting of the precast beams as shown in Figure 3.1.2b. If continuity bars of the same diameter of the current longitudinal ones of the column are used in the joint, this solution weakens locally the flexural capacity of the column with detrimental effects on the frame behaviour of the structure under seismic action. Like the use of superimposed segments of column jointed at the floors levels, this latter solution can be used in structures braced by walls or cores (wall systems) where the columns are mainly subjected to axial action without relevant bending moments. To save the uniform continuity of the flexural resistance of the column through the joint in frame systems, continuity bars of a bigger diameter can be used.

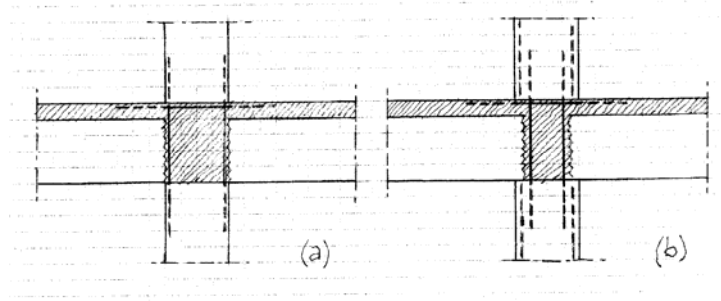

Figure 3.1.2

With respect to the sketches of Figures 3.1.1 and 3.1.2 proper stirrups shall be added within the joints. The detailing of the joint may be differently laid out depending on the type of connected elements and on the arrangement of the connection.

3.1.2 Strength

Strength verifications of the connections of concern refer mainly to the adequate anchorage of the overlapped bars within the joints. For these verifications reference can be made to Clause 8.4 of *EC2*. To avoid a brittle bond failure it is necessary to over-proportion the anchorage length by capacity design with respect to the full tensile strength of the overlapped bars. Shear verification of the beam end shall be made following the ordinary calculation model of *EC8*.

The following sub-clauses give more detailed rules for the only arrangement tested within Safecast Project that is the one described in Figure 3.1.2. In particular the tested prototypes had only one beam laterally connected to a passing column..

3.1.2.1 Behaviour models

This type of connection provides a monolithic union of the beam on the joint, ensuring a full support with the transmission of internal forces and moments. The usual models for the verification of shear and bending moment of cast-in-situ structural elements apply.

3.1.2.2 Failure modes

- a – Flexural failure of the connection referred to the yielding of the longitudinal tensioned bars;
- b – Bond failure of the anchorage of the tensioned bars;
- c – Longitudinal shear failure at the interface between the precast beam and the cast-in-situ slab.

The shear strength of the beam shall be over-proportioned by capacity design with respect to the flexural strength of its end sections.

3.1.2.3 Calculation formulae

The ultimate resisting moment (positive or negative) can be calculated by

$$M_{Rd} = A_{st} f_{yd} z \qquad f_{yd} = f_{yk} / \gamma_S^*$$

with

$$z = d - x/2 \qquad x = A_{st} f_{yd} / (b f_{cd}) \qquad f_{cd} = f_{ck} / \gamma_C^*$$

where A_{st} is the sectional area of the tensioned reinforcement, f_{yk} is its characteristic yielding stress, d is the effective depth of the beam section, b is the width of its compressed chord and f_{ck} is the characteristic compressive strength of concrete.

a – flexure

$$M_{Rd} \geq M_{Ed}$$

where M_{Ed} is the design value coming from the structural analysis. For the design of the frame resisting system under seismic action, the resisting moment M_{Rd} could enter in the capacity design calculation together with the competent resisting moments of the other members convergent in the node.

b – bar anchorage

(l_b anchorage length of a bar in the upper slab, A_s its sectional area, u its perimeter, f_{ctd} design tensile strength of the cast-in-situ concrete, f_{yk} characteristic yield strength of steel)

$$l_b u f_{bd} \geq \gamma_R A_s f_{ym}$$

where

$$f_{bd} = 2,25 f_{ctd} \quad \text{ultimate bond strength (see 8.4.2 of EC2)}$$

$$f_{ym} = 1,08 f_{yk} \quad \text{mean yielding stress of the steel}$$

c – longitudinal shear

(A_{ss} total sectional area of the protruding stirrups available in the end segment long h of beam)

$$A_{ss} f_{yd} \geq \gamma_R A_{st} f_{ym}^\circ$$

* The values $\gamma_C=1,5$ and $\gamma_S=1,15$ are recommended by EC2.

° The values $\gamma_R=1,2$ for DCM and $\gamma_R=1,35$ for DCH are recommended by EC8.

3.1.2.4 Any other data

For the arrangements described in Figure 3.1.1, due to the uncertain stressing of the bars within the overlapping length, it is difficult to evaluate a precise yielding limit moment of the sections in the joint. For this reason it is preferable to over-design the connections following Clause 5.11.2.1.2 of EC8. The

connection can be assumed as energy dissipating if the conditions of Clause 5.11.2.1.3 of *EC8* are met. In the case (c) of Figure 3.1.1 Clause 5.11.2.1.1 of *EC8* may be applied.

3.1.3 Ductility

For the arrangement of Figure 3.1.2, in testing a displacement ductility over 4,0 has been always measured. This refers to the testing arrangement that includes a relevant part of the beam so that the measurements refer mainly to the flexural contribution of the beam.

In general it can be assumed that this type of connection, if properly designed following the rules given above, saves the full capacities of the beam (between **medium** and **high ductility**).

3.1.4 Dissipation

Cyclic tests performed on the arrangement of Figure 3.1.2 show a **medium dissipation** capacity that is to be attributed to the beam.

3.1.5 Deformation

In cyclic tests drifts of about 1,5% have been reached for positive moments (upper slab in compression), of about 2% for negative moments (upper slab in tension).

3.1.6 Decay

Limited strength decay has been measured after the three cycles of any amplitude before failure.

3.1.7 Damage

For drifts larger than 1%, relative rotations have been observed between the beam and the column. Plastic flexural deformations occurred in the beam for higher drifts with the yielding of the longitudinal tensioned bars. Shear cracks penetration into the joint has also been observed.

3.2 CONNECTIONS WITH DOWELS

3.2.1 General

Figure 3.2.1 shows the end connection of a beam to a supporting column. In the case (a) two dowels protrude from the top of the column and enter into the sleeves inserted in the beam. The sleeves are filled with no-shrinkage mortar of adequate strength to ensure by bond the anchorage of the dowels. The anchorage can also be ensured providing the dowels with a cap fixed at the top with a screwed nut. In any case the sleeve shall be filled in with mortar to avoid hammering under earthquake conditions. The case (b) refers to the same technology but with only one dowel. In the transverse direction the use of two dowels improve the resistance against overturning moments. Due the much lower stability against overturning moments the use of one only dowel is not recommended especially with reference to the uneven load conditions during the construction stages.

The beam usually is placed over a pad to localise the load (see 3). If deformable rubber pads are used, due to their much lower stiffness all the loads applied after their bond anchorage will be conveyed into the steel dowels. And this will cause a local splitting damage of the concrete around the dowels. The use of rigid steel pads will prevent this effect. To avoid local splitting damage, rubber pads can be used with non-adherent dowels, but this would require a different device to transfer horizontal seismic actions without hammering. The rules given in the following clauses are based on tests made only on connections with flexible rubber pads and adherent dowels.

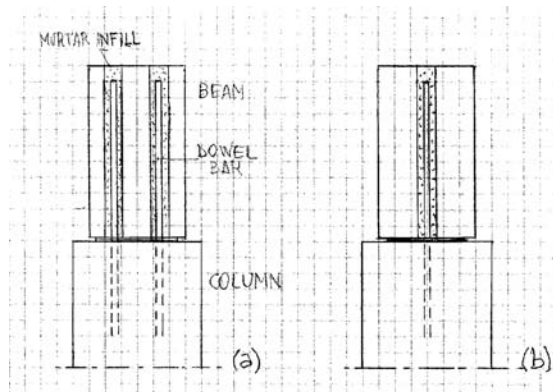

Figure 3.2.1

As a general rule, a proper confinement shall be provided at the column top with additional stirrups and steel links. At the beam edge horizontal anchored hooks in front of the dowels shall be provided in order to restrain them in case of spalling of the concrete cover.

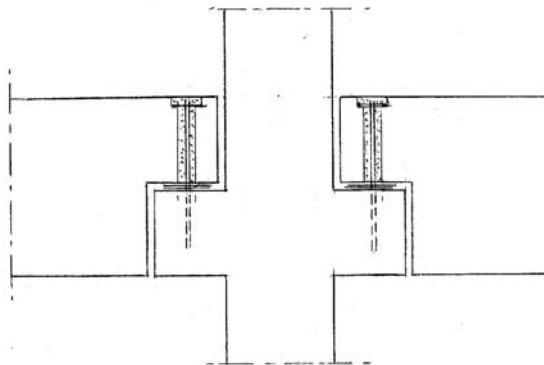

Figure 3.2.2

A similar behaviour with the same design criteria have the beam-to-column connections placed at the intermediate floors over corbels standing out from the column. In particular Figure 3.2.2 shows one of these connections with the solution of half joints that keeps the corbel within the depth of the supported beam.

3.2.2 Strength

The following indications about the mechanical behaviour of this type of connection leaves out of consideration the friction that sets up between the parts due to the weight of the supported element. In fact in seismic conditions, under the contemporary horizontal and vertical shakes, the connection shall work instantly also in absence of weight.

3.2.2.1 Behaviour models

This type of connection provides an hinged support in the vertical plane of the beam and a full support in the orthogonal vertical plane. In the longitudinal direction of the beam the horizontal force R is transmitted through the shear resistance of the connection (see Figure 3.2.3a), which is given by the shear resistance of the dowels and their local flexure between the elements in correspondence of the bearing pad. In the transverse direction, omitting the vertical gravity loads, the connection transmits a shear force V together with the corresponding moment M (see Figure 3.2.3b).

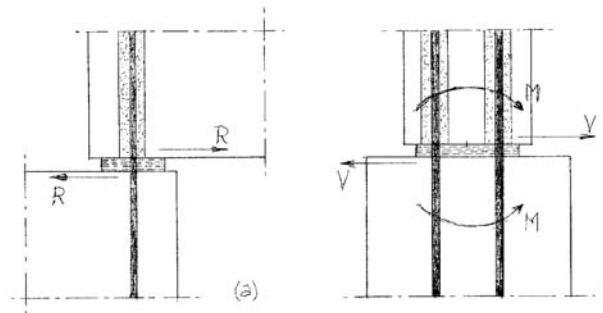

Figure 3.2.3

3.2.2.2 Failure modes

The principal failure modes for longitudinal action are listed hereunder:

- a – breaking of the dowel connection due to combined shear, tension and flexure on steel bar and bearing stresses on concrete;
- b – spalling of the concrete edge of the beam due to tensile stresses;
- c – spalling of the concrete edge of the column due to tensile stresses.

The principal failure modes for transverse action are listed hereunder:

- d – flexural failure of the bearing section due to the action of M ;
- e – pull-out of the tensioned dowel under the action due to M ;
- f – sliding shear failure under the action of V .

3.2.2.3 Calculation formulae

With reference to Figure 3.2.3a, for the action of a given force R evaluated by capacity design with respect to the resistance of the critical sections of the structure using the due overstrength factor γ_R° , the following verifications shall be made.

For spalling of concrete edges, the equations taken from TS2 are suggested in points (b) and (c) as possible resistance verification.

a – dowel

(with n number of dowels, ϕ diameter of dowels, f_{ck} characteristic compressive strength of concrete, f_{yk} characteristic yield strength of steel, $\alpha = \sigma / f_{yk}$ with σ normal tensile stress due to other possible contemporary effects on the dowel)

$$R_d = 0,90 n \phi^2 \sqrt{[f_{yd} f_{cd} (1 - \alpha^2)]}$$

$$R_{Rd} \geq R \quad \text{with } f_{cd} = f_{ck} / \gamma_C \text{ and } f_{yd} = f_{yk} / \gamma_S^*$$

* If the rotation of the joint is prevented by the stiffness of the connected elements, the numerical factor can be taken to 1,0.

b – beam edge

($f_{ck,cube}$ characteristic compressive cubic strength of concrete, ϕ diameter of the dowel, c edge distance of the dowel axis, $h = 8\phi$ effective length of the dowel, b width of the column, n number of dowels)

$$R_{RK} = 1,4 k \phi^\alpha h^\beta \sqrt{(f_{ck,cube} c^3)} \psi_{re} \quad \alpha = 0,1 (h / c)^{0,5} \quad \beta = 0,1 (\phi / c)^{0,2}$$

$$(R / R_{Rd}) \leq 1 \quad (R_{Rd} = R_{RK} / \gamma_C)^\wedge \quad k = b / (3 c) \leq n$$

where $f_{ck,cube}$ is expressed in N/mm², R and R_{RK} in N and d , h , c , b , ϕ in mm and $\psi_{re} = 1,4$ in presence of edge reinforcement as specified in 3.2.2.4, or $\psi_{re} = 1,0$ in all other cases.

c – column edge

($f_{ck,cube}$ characteristic compressive cubic strength of concrete, ϕ diameter of the dowel, c edge distance of the dowel axis, $h = 8\phi$ effective length of the dowel, b width of the column, n number of dowels)

$$R_{RK} = 1,4 k \phi^\alpha h^\beta \sqrt{(f_{ck,cube} c^3)} \psi_{re} \quad \alpha = 0,1 (h / c)^{0,5} \quad \beta = 0,1 (\phi / c)^{0,2}$$

$$(R / R_{Rd}) \leq 1 \quad (R_{Rd} = R_{RK} / \gamma_C)^\wedge \quad k = b / (3 c) \leq n$$

where $f_{ck,cube}$ is expressed in N/mm², R and R_{RK} in N and d , h , c , ϕ in mm and $\psi_{re} = 1,4$ in presence of edge reinforcement as specified in 3.2.2.4, or $\psi_{re} = 1,0$ in all other cases.

^ The value $\gamma_C = 1,5$ is recommended by EC2 (see also TS4).

With reference to Figure 3.2.3b, for the action of a force V and a moment M evaluated by capacity design with respect to the resistance of the critical sections of the structure using the due overstrength factor γ_R° , the following verifications shall be made.

d – flexure

(A_s sectional area of the dowel, f_{yk} characteristic yield strength of steel, z lever arm of the couple)

of forces in the bearing print)

$$M_{Rd} = A_s f_{yd} z \geq M \quad (z \approx d \text{ may be assumed with } d \text{ spacing of the two dowels})$$

$$\text{with } f_{yd} = f_{yk} / \gamma_S^*$$

e – pull-out

(l_b anchorage length of the dowels in the beam, A_s sectional area of a dowel, u its perimeter, f_{md} design cylinder compressive strength of the mortar, f_{yk} characteristic yield strength of steel)

$$l_b u f_{bd} \geq \gamma_R A_s f_{ym}$$

where

$$f_{bd} = 0,45 f_{md} \quad \text{ultimate bond strength}$$

$$f_{ym} = 1,08 f_{yk} \quad \text{mean yielding stress of the steel}$$

f – sliding shear

(b width of the bearing print, x depth of its compressed part, f_{ck} characteristic compressive strength of concrete of the beam or of the column if lower, A_s area of the dowels not yielded by the contemporary flexure, f_{yk} characteristic yield strength of steel)

$$V_{Rd} \geq V \quad \text{with} \quad V_{Rd} = V_{dd} + V_{fd} \quad \text{where}$$

$$V_{dd} = 1,3 A_s \sqrt{f_{cd} f_{yd}} \quad \text{resistance of the shear resisting (compressed) dowel}$$

$$V_{fd} = 0,25 b x f_{cd} \quad \text{sliding resistance of the compressed concrete}$$

$$\text{with } f_{cd} = f_{ck} / \gamma_C \text{ and } f_{yd} = f_{yk} / \gamma_S^*$$

° The values $\gamma_R=1,2$ for DCM and $\gamma_R=1,35$ for DCH are recommended by EC8.

* The values $\gamma_C=1,5$ and $\gamma_S=1,15$ are recommended by EC2.

3.2.2.4 Any other data

Failure mode *b* related to a tensile cracking of the concrete edge of the beam corresponds to the weakest mechanisms indicatively for $c/\phi < 6$ with c edge distance of the dowel axis. For $c/\phi \geq 6$ failure mode *a* related to the dowel strength is the weakest one.

In the beam the ordinary longitudinal reinforcement made of bars of large diameter does not prevent the concrete spalling also if these bars are well anchored by hooks bended at 135° : in fact the bars enter upon effect only after the cracking of concrete, but at this point the support can be jeopardized. In order to control the crack opening and prevent the failure by spalling, an effective edge reinforcement shall be added made of small diameter U-shape horizontal links closely distributed along the lower part of the beam. These horizontal links are particularly important for small c/ϕ values as they restrain the dowels after the cracking of concrete. They shall be distributed over 8ϕ from the bottom with a spacing not greater than 50 mm and dimensioned for a design resistance equal to the expected action.

To prevent the edge the failure by spalling of the column a closely spaced distribution of confining stirrups shall be placed at the top end together with steel links to the dowels and a grid of bars at the upper face. For a height equal to the larger side of the cross section, the stirrups shall be distributed with a spacing not greater than 100 mm and a confining volumetric mechanical ratio of at least 0,08. The steel links shall be placed in the direction of the action, distributed within 8ϕ from the top of the column for a $2c$ width around the dowels and dimensioned for a design resistance equal to the expected action.

Calculation formulae of cases *a*, *b* and *c* refer to the use of flexible rubber bearing pads. Rigid steel pads have not been tested in the present research.

3.2.3 Ductility

In testing, failure mode *a* of dowel connection displayed a local shear ductility, due to the flexural and tensional deformation of the dowels within the joint gap, evaluated in

$$\mu = 4,0 \text{ to } 6,0 \quad \text{for } c/\phi \geq 6$$

$$\mu = 2,5 \text{ to } 3,5 \quad \text{for } c/\phi < 6$$

But often an early brittle spalling of the beam edge occurred. With a sufficient bearing length, spalling can be not prejudicial for the stability of the support.

3.2.4 Dissipation

Cyclic tests performed in the longitudinal direction of the beam show a **medium dissipation** capacity due to the alternate deformations of the dowels within the joint gap. For small thicknesses of this gap the dissipation capacity would decrease sensibly. Also crushing of the concrete around the dowels occurs for large shear displacements reducing the energy dissipation capacity.

In any case, due to their location in the structural assembly and to their high stiffness in comparison to the column flexibility, no contribution of ductility and dissipation are expected from this type of connections to the global ductility of the structure. They shall be over-proportioned by capacity design with respect to the critical sections of the column base.

3.2.5 Deformation

In cyclic tests relative displacements up to ± 36 mm have been reached at the ultimate amplitudes before failure.

3.2.6 Decay

Cyclic tests show that, at any displacement level before failure, strength decay occurs after each of the three cycles. At the third cycle this strength decay can reach the 25% of the value of the first cycle.

3.2.7 Damage

Damage is associated with spalling of the concrete beam end, splitting of the concrete at both beam and column and breaking of the dowels. Typically, the first two modes of damage lead to a reduction of the shear resistance but not to failure.

Where bearing pads are used, failure occurs with the tensile rupture of the dowels after large plastic deformations. Depending on the diameter of the dowels and the ratio c/ϕ , dowels can break after or before significant spalling at the concrete edges. The breaking point is usually located at a depth, approximately

equal to 2ϕ within the beam or the column. As a result, breaking of the dowels does not necessarily lead to a total loss of resistance, since a portion of the broken dowels extrudes from the column or the beam inside the opposite element and continues to pose significant resistance against horizontal movement.

3.3 CONNECTIONS WITH MECHANICAL COUPLERS

3.3.1 General

This type of connections refers to over-designed mechanical devices that realize the flexural continuity between the connected members through high resistance bolts. The gap is filled with high resistance no-shrinkage mortar to ensure the continuity with the members' concrete. The mortar shall have at least the same resistance of the concrete. Figure 3.3.1 shows in plan and elevation the end connection of a beam to a column in the typical arrangement of a half-joint

The details of the coupling devices are shown in Figure 3.3.2. In the case (a) of this figure the reinforcing bars are connected to two plates placed in each member. Bolts are placed between the plates to realize the connection. In the case (b) one plate, to which the reinforcing bars are fixed, is placed on the beam, while the column is provided with a reinforcement with a threaded end, in which the coupling bolt is directly screwed.

If the concrete section is sensibly weakened by slots for the installation of the bolt(s), the section shall be restored and properly confined.

This type of connection is normally used in combination with dowels (see 3.2) and can be activated in a second stage during erection. In the latter case, transitory construction phases have to be checked.

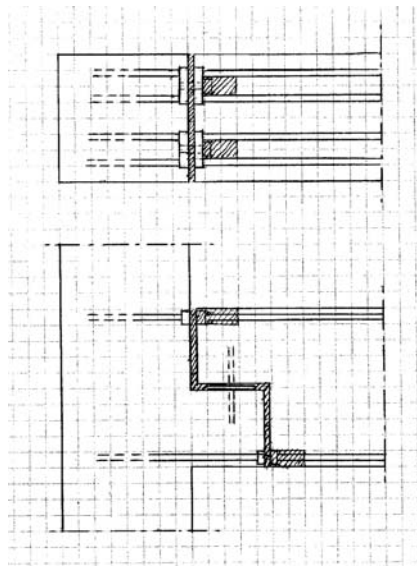

Figure 3.3.1

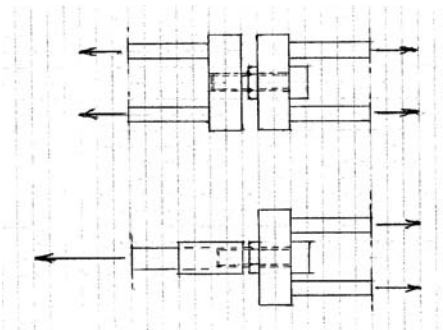

Figure 3.3.2

3.3.2 Strength

3.3.2.1 Behaviour models

This type of connection provides a clamped support. The bolts are mainly acting in tension. In some cases they can also act in compression (if a proper counter-nut is provided). In the longitudinal direction, the horizontal force due to the bending moment is directly transmitted to the reinforcing bars through the connection. The mortar filling acts in compression under flexure.

The shear force coming from the beam is assumed to go entirely on the corbel standing out from the column. Proper detailing shall be provided for the reinforcement of the corbel and the beam end following EC2 design rules.

Since normally this type of connection is used in addition to dowels, the horizontal shear transmission and the flexural transverse resistance are still carried by the dowels. When the mortar filling is hardened, the union between the beam and the joint can be considered as monolithic.

3.3.2.2 Failure modes

The principal failure modes are listed hereunder:

- a – breaking of the coupler (bolt);
- b – excessive deformation of the supporting plate(s);
- c – detachment of the reinforcing bars;

3.3.2.3 Calculation formulae

This type of connection is placed in critical zone. With reference to Figure 3.3.2, for the action of a force evaluated by capacity design with respect to the greater between the resistance of the two reinforcements connected by the coupler using the due over-strength factor, the following verifications shall be made.

- a – coupler (non ductile)
provided that the threaded length and the washers are correctly designed, the coupler shall be over-designed as follows:

(F_{Rmin} minimum steel ultimate capacity of the fastener declared by the producer)

$$F_{Rmin} \geq \gamma_R A_s f_{ym}$$

A_s maximum sectional area between the two corresponding upper reinforcements

where

$f_{ym} = 1,08 f_{yk}$ mean yielding stress of the steel bars (f_{yk} their characteristic yielding stress)

- b – plate(s)

the plate shall be over-proportioned in thickness in order to avoid sensible deformation at failure limit.

- c – reinforcement

a proper connection between the reinforcement and the plate(s) shall be designed by initial type testing. In case of direct welding, special care and controls are suggested to avoid weakening of the reinforcement.

The values $\gamma_R=1,2$ for DCM and $\gamma_R=1,35$ for DCH are recommended by EC8.

3.3.2.4 Any other data

Since this type of connection is over-resisting, failure is expected to occur away from the connection (in the current reinforcement). Since high resistance bolts are usually adopted as couplers, their cross section can be less than the one of the reinforcement they are linking. Thus, flexural cracks are expected to open also within the connection. The cracked stiffness of the member should be calculated considering the cross section in correspondence of the couplers.

Special care is suggested for the mortar filling process, especially if dealing with complex three dimensional surfaces and small gaps.

3.3.3 Ductility

The ductility of the member is not influenced by the connection, which is over-resisting and designed to remain in elastic field.

3.3.4 Dissipation

The energy dissipation of the structure does not depend on the contribution of the connection itself. Anyway, local damage of the mortar or other effects can create a permanent gap in the joint, affecting the cyclic performance of the connection. Double nuts are suggested to be used to reduce this effect (making the bolt acting also in compression). High tightening moments can be used to delay the decompression and the opening of the joint.

3.3.5 Deformation

A slightly larger flexural deformation of the member with this type of connection, if compared to a cast-in-situ solution, is expected, due to the elastic elongation of the coupling bolts.

3.3.6 Decay

Cyclic tests show that at any displacement level before failure no relevant strength decay displays after the three cycles.

3.3.7 Damage

Failure is expected to occur out of the connection, while damage (cracking) occurs also the joint.

3.4 HYBRID CONNECTIONS

3.4.1 General

Figure 3.4.1 shows the end connections of beams to the corbels standing out from a supporting column. The term “hybrid” refers to the connection arrangement made at the upper part with additional bars and cast-in-situ concrete proper of an emulative joint and at the lower part with mechanical steel devices proper of a typical joint. The upper cast-in-situ slab is connected to the precast beams by the protruding stirrups that resist the longitudinal shear transmitted through the interface. The lower connection can be made with the welded solution described in Clause 2.4 for a rib of a floor element providing for the proper dimensional adaptations.

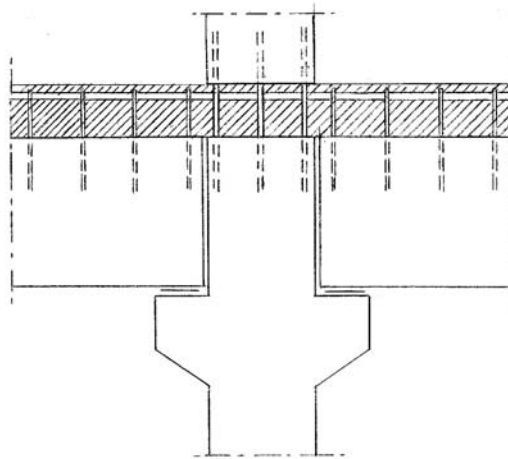

Figure 3.4.1

3.4.2 Strength

This type of connection, after the hardening of the cast-in-situ concrete slab, provides a moment resisting support between the parts, with a dissymmetrical behaviour for positive and negative moments. The loads applied after the hardening of the slab take their action on this moment resisting connection. The self weight of the beam, included the upper concrete slab, acts on a simple hinged support arrangement.

3.4.2.1 Behaviour models

In both stages of hinged and fixed support, the shear force coming from the beam is assumed to go entirely on the corbel standing out from the column. The local detailing and design calculation of the corbel shall be made following the provisions of *EC2*.

Figures 3.4.2a-b show the resisting mechanisms respectively for negative and positive moments. In the first mechanism the tensile force Z acts in the longitudinal bars added in the cast-in-situ upper slab and the compressive force $C (=Z)$ comes from the bottom weldings with a lever arm z' . In the second mechanism the compressive force C acts in the cast-in-situ upper slab and the tensile force $Z (=C)$ comes from the bottom weldings with a lever arm z .

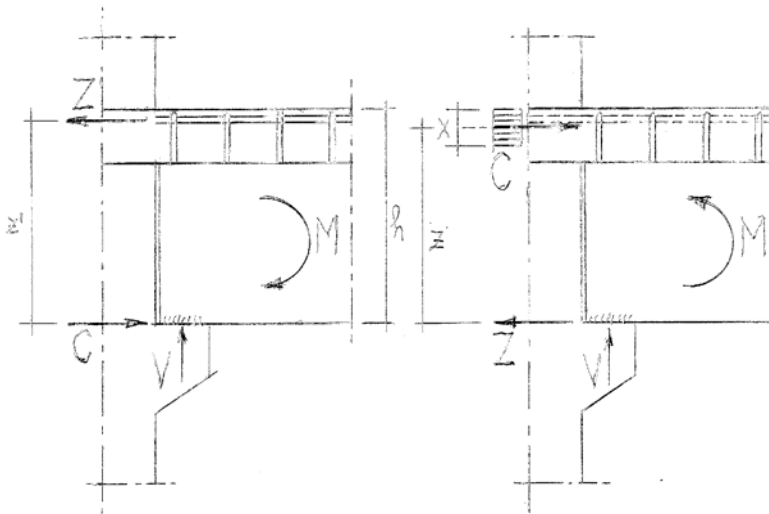

Figure 3.4.2

3.4.2.2 Failure modes

For a negative moment the principal failure modes are listed hereunder.

- a - flexural failure of the connection referred to the yielding of the longitudinal upper bars;
- b – bond failure of the anchorage of the upper bars;
- c – longitudinal shear failure at the interface between precast beam and cast-in-situ slab;
- d – failure of the bottom connection between the rib and the supporting corbel.

For a positive moment the principal failure modes are listed hereunder.

- e – flexural failure of the connection referred to the rupture of the bottom connection;
- f – longitudinal shear failure of the interface between precast beam and cast-in-situ slab;

3.4.2.3 Calculation formulae

For a positive moment (see Figure 3.4.2a) the ultimate resisting value (with A_{st} total sectional area of the longitudinal upper bars) can be calculated by:

$$M_{Rd} = A_{st} f_{yd} z' \qquad f_{yd} = f_{yk} / \gamma_S^*$$

a – flexure

$$M_{Rd} \geq M_{Ed}$$

where M_{Ed} is the design value coming from the structural analysis. For the design of the frame resisting system under seismic action, the resisting moment M_{Rd} could enter in the capacity design calculation together with the competent resisting moments of the other members convergent in the node.

b – bar anchorage

(l_b anchorage length of a bar in the upper slab, A_s its sectional area, u its perimeter, f_{ctd} design tensile strength of the cast-in-situ concrete, f_{yk} characteristic yield strength of steel)

$$l_b u f_{bd} \geq \gamma_R A_s f_{ym}$$

where

$$f_{bd} = 2,25 f_{ctd} \quad \text{ultimate bond strength (see 8.4.2 of EC2)}$$

$$f_{ym} = 1,08 f_{yk} \quad \text{mean yielding stress of the steel}$$

c – longitudinal shear

(A_{ss} total sectional area of the protruding stirrups available in the end segment long h of beam)

$$A_{ss} f_{yd} \geq \gamma_R A_{st} f_{ym}$$

d – bottom connection

verifications a-b-c of point 2.4.2.3 shall be applied referring to an acting force $R = \gamma_R A_{st} f_{ym}$.

For a positive moment (see Figure 3.4.2b) the resisting value can be calculated by

$$M_{Rd} = R_R z$$

with

$$z = h - x/2 \leq 0,96 h \quad x = R_R / (f_{cd} b)$$

where R_R is the minimum resistance of the bottom connection calculated from all the failure modes covered by 2.4.2.3 and b is the collaborating width of the upper slab.

e – flexure

$$M_{Rd} \geq \gamma_R M_{Ed}$$

where M_{Ed} is the design value coming from the structural analysis

f – longitudinal shear

(A_{ss} total sectional area of the protruding stirrups available in the end segment long h of the beam)

$$A_{ss} f_{yd} \geq \gamma_R R_R$$

3.4.2.4 Any other data

For positive moments a ductile flexural behaviour can be provided by the end segment of the beam with its lower longitudinal reinforcement, the welded connection being overdimensioned.

3.4.3 Ductility

In testing a displacement ductility over 3,5 has been always measured. This refers to the testing arrangement that includes a relevant part of the beam so that the measurements refer mainly to the flexural contribution of the beam. The connection itself is expected to display a good ductility for negative moments, coincident with the beam ductility, and display no relevant ductility for positive moments. If the bottom connection is overdimensioned by capacity design, this latter behaviour does not endanger the ductility capacities of the beam.

In general it can be assumed that this type of connection, if properly designed following the rules given above, saves the full capacities of the beam (between **medium** and **high ductility**).

3.4.4 Dissipation

Cyclic tests performed show a **medium dissipation** capacity that is to be attributed to the beam.

3.4.5 Deformation

In cyclic tests drifts of about 2% have been reached for positive moments (upper slab in compression), of about 1% for negative moments (upper slab in tension).

3.4.6 Decay

Limited strength decay has been measured after the three cycles of any amplitude before failure.

3.4.7 Damage

For drifts larger than 1%, relative rotations have been observed between the beam and the column. Plastic flexural deformations occurred in the beam for higher drifts with the yielding of the longitudinal tensioned bars.

4 COLUMN-TO-FOUNDATION CONNECTIONS (ORDER 5)

4.1 POCKET FOUNDATIONS

Figure 4.1.1 shows two possible solutions for the connection of a column to the supporting foundation. For both solutions the column is inserted within the pocket delimited by the four walls of the foundation. It is placed on a pad over the bottom footing slab. After the centring of the column, fixed with proper provisional bracing props, the bottom gap to the footing and the peripheral gap to the walls are filled with no-shrinkage mortar. The pocket shall be large enough to enable a good compacted filling below and around the column. In the left solution the surfaces of column and foundation within the joint are smooth. In the right solution they are wrought with indentations or keys so to increase the adherence of the mortar.

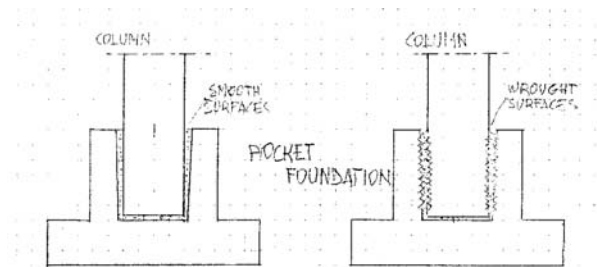

Figure 4.1.1

For sway frames, where the stability of the structure relies on the flexural strength of the column, a minimum insertion depth of the column is recommended with $l \geq 1,2h$, where l is the insertion depth and h is the maximum side of the column section.

4.1.2 Strength

For sway frames, the connection shall be verified for the action of the (plastic) ultimate moment $M_{Rd} = M_{Rd}(N)$ of the adjacent column section with the correspondent contemporary axial force N and of shear V . This calculation can be performed in the two main directions independently. The due overstrength factor γ_R° shall be added with $\gamma_R M_{Rd}$, N and $\gamma_R V$.

The verification rules can be taken from Clause 10.9.6 of EC2. In particular pocket foundations with wrought surfaces are assumed as monolithic and the verification refers mainly to the proper overlapping of the vertical bars of column and pocket walls. For pocket foundations with smooth surfaces a behaviour model referred mainly to a system of reaction forces orthogonal to the adjacent surfaces can be adopted.

^o The values $\gamma_R = 1,2$ for DCM and $\gamma_R = 1,35$ for DCH are recommended by EC8.

4.1.3 Other properties

No specific parameters of seismic behaviour (ductility, dissipation, deformation, decay, damage) have been experimentally measured for this type of connection, for which no ductility and dissipation capacities are expected.

4.2 FOUNDATIONS WITH PROTRUDING BARS

4.2.1 General

Figure 4.2.1 shows the connection of a column to the foundation obtained by the anchorage of the reinforcing longitudinal bars protruding from the base of the column within the corrugated sleeves inserted in the foundation and filled with no-shrinkage mortar. Due to their size (80 to 100 mm of diameter) the sleeves jut out of the column profile in the wider dimension of the foundation element so that the longitudinal bars can enter without deviating from their straight peripheral position in the column.

The column itself settles on a bed of mortar that fills the joint up. This bed shall be sufficiently thin to avoid the buckling of the bars within the gap when subjected to strong compression, otherwise a proper confining reinforcement shall be added.

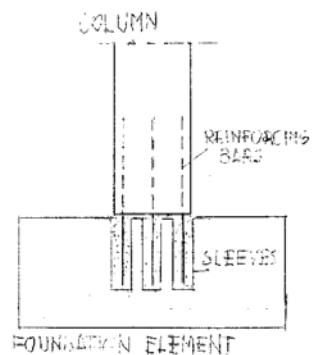

Figure 4.2.1

The steel reinforcement inside the column doesn't need any special adaptation for the connection. The length of the protruding part of the bars shall be over-proportioned by capacity design to avoid a brittle bond failure of the anchorage before the yielding of the bars in the critical region at the base of the column. The protruding bars shall be protected during transportation to avoid their accidental distortion.

An alternative solution keeps the protruding parts of the bars separated. Just before the installation in site of the column, these cropped parts are screwed in a bush previously fixed at the end of the internal part of the longitudinal reinforcement. The threading weakens the bars and can jeopardise the strength of the connection, leading to an early brittle failure. Special technological provisions shall be adopted to save the strength hierarchy of the connection devices that allows to display the full ductility resources of the column.

Proper reinforcement shall be placed in the foundation element to confine the concrete around the sleeves and anchor them against pull-out. The sleeves shall be filled with fluid mortar just before the placing of the column, which verticality shall be adjusted with timber wedges driven at the base and ensured by lateral provisional props until the hardening and sufficient aging of the mortar.

4.2.2 Strength

The connection shall be verified for the action of the (plastic) ultimate moment $M_{Rd}=M_{Rd}(N)$ of the adjacent column section with the correspondent contemporary axial force N and of shear V . This calculation can be performed in the two main directions independently. The due overstrength factor γ_R shall be added as specified below.

4.2.2.1 Behaviour models

Figure 4.2.2 shows the detail of the resisting mechanism of the foot section of the column subjected to the combined bending moment M_{Rd} and axial action N and to the shear V . Assuming that at this level of action the tensile reinforcement is yielded, the anchorage verification shall be referred to a pull-out force correspondent to the mean yielding stress f_{ym} of the bar and to a fully confined mortar.

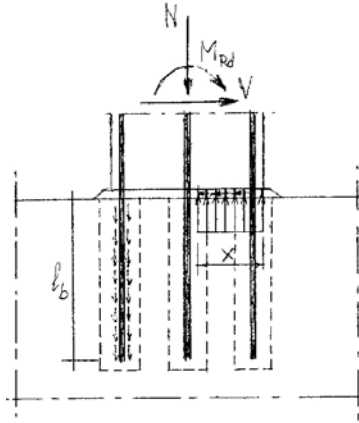

Figure 4.2.2

4.2.2.2 Failure modes

The failure modes are listed hereunder:

- a – pull-out of the tensioned bars of the foot section under the combined action of $\gamma_R M_{Rd}$ and N ;
- b – sliding shear failure at the foot section in the design situation corresponding to $\gamma_R M_{Rd}$, N and $\gamma_R V$.

4.2.2.3 Calculation formulae

With reference to the symbols described in Figure 4.2.2 and with γ_R overstrength factor °, the following verifications shall be performed.

- a – pull-out
(l_b anchorage length of the bar)

$$l_b \text{ u } f_{bd} \geq \gamma_R A_s f_{ym}$$

where

$$u = \pi \phi' \quad \text{perimeter of the protruding bar section (} \phi' \text{ its diameter)}$$

$$A_s = \pi \phi^2 / 4 \quad \text{area of the upper bar section (} \phi \text{ its diameter)}$$

$$f_{bd} = 0,45 f_{md} \quad \text{ultimate bond stress (} f_{md} \text{ design cylinder compressive strength of the mortar)}$$

$$f_{ym} = 1,08 f_{yk} \quad \text{mean yielding stress of the steel upper bar (} f_{yk} \text{ its characteristic yielding stress)}$$

- b – sliding shear
(b width of the section, x depth of its compressed part, f_{cd} design compressive strength of the mortar

or of the column concrete if lower, A_d area of the bars not yielded by the contemporary flexure and f'_{yd} steel design yielding stress of the protruding bars)

$$V_{Rd} \geq V \quad \text{with} \quad V_{Rd} = V_{dd} + V_{fd}$$

($V = V(\gamma_R M_{Rd})$ is the shear corresponding to $\gamma_R M_{Rd}$)

where

$$V_{dd} = 1,3 A_d \sqrt{f_{cd} f'_{yd}} \quad \text{dowel resistance of the shear resisting bars}$$

$$V_{fd} = 0,5 b \times f'_{cd} \quad \text{sliding resistance of the compressed mortar (or concrete)}$$

$$f'_{cd} \approx 0,5 f_{cd}$$

° The values $\gamma_R=1,2$ for DCM and $\gamma_R=1,35$ for DCH are recommended by EC8.

4.2.2.4 Any other data

Provided the overstrength rules of 4.2.2.3 are applied, the base connection with protruding bars leaves almost unchanged the strength/ductility properties of the column as for a monolithic cast-in-situ connection. The connection of cropped bars, post-installed by coupling devices (bushes) to the main reinforcement, shall be verified by testing for its effectiveness in terms of over-resistance with respect to the connected bars.

4.2.3 Ductility

In testing, performed with cropped post-installed bars, the failure modes listed in 4.2.2.2 have not been reached. Failure occurred after the formation of a plastic hinge at the base of the column with large cyclic deformations and has been produced by the localised rupture of a cropped bar at its threaded end. With reference to the overall assembly foundation-connection-column, the ductility factor experimentally determined has been

$$\mu_\phi \approx 6,0 \quad \text{in terms of curvature of the column base}$$

$$\mu_\delta \approx 3,0 \quad \text{in terms of top displacement of the column}$$

The correspondent classification in **medium ductility** refers by consequence to the column capacities and has been limited by the capacity of the coupling details of the cropped bars.

4.2.4 Dissipation

Cyclic tests performed on the overall assembly foundation-connection-column show an initial **low dissipation** capacity that increases with the cycle amplitudes up to a **medium dissipation** capacity at the last cycles before failure. This behaviour is to be attributed mainly to the column, but is affected also by the alternate opening of the base joint.

4.2.5 Deformation

In cyclic testing ultimate drifts due to the column deformation and partly to the opening of the base joint interface of about 4,5 % have been reached.

4.2.6 Decay

Cyclic tests show that at any displacement level before failure no relevant strength decay displays after the three cycles.

4.2.7 Damage

At serviceability limit state, taken as 1 % of drift, an elastic behaviour with no sensible residual deformations as been registered. The yielding limit set at about 1,5 % of drift. At 3,0 % of drift relevant damage has disclosed by a widespread cracking of the column with about 30 % of residual deformation at unloading and a residual mean opening of about 2,1 mm at the base joint interface.

Failure occurred at about 4,5 of drift % with wide spalling of the concrete corners, buckling of bars within the joint gap and the rupture of the threaded end of cropped bars just under of the coupling bush.

4.3 FOUNDATIONS WITH BOLTED SOCKETS

4.3.1 General

Figure 4.3.1 shows the connection of a column to the foundation obtained through steel sockets inserted in the column base and bolted to the foundation. The sockets are anchored to the column by means of couples of bars welded to them and spliced to the current longitudinal reinforcement by lapping. Other transverse links can be welded to the sockets to avoid their lateral detaching.

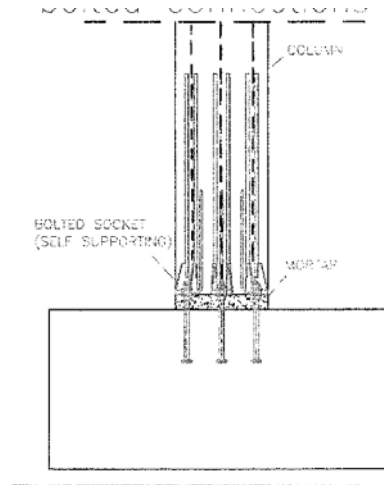

Figure 4.3.1

At the lower part of the connections, stud-bolts are protruding from the foundation, one for any socket. They consist of headed fasteners of adequate length previously embedded in the foundation element. The coupling of fasteners and sockets through their holes requires tightened tolerances in execution, both of the column and the foundation, for what concerns their positioning. The use of pre-perforated counter-plates as temporary templates can be useful.

At installation stage the column can be supported by lock-nuts screwed on the fasteners, by which its verticality can be adjusted and maintained without the need of provisional props. The installation is completed with the tightening of the upper nuts and the casting of the mortar embedding to fill the joint between the column base and the foundation. This bed shall be sufficiently thin to avoid the buckling of the fasteners within the gap when subjected to strong compression, otherwise a proper confining reinforcement shall be added.

The devices of this type of connection are usually covered by specific patents and can be differently organised on the base of the same coupling principle. They shall be submitted to initial testing to verify their behaviour and the ductility capacity of the overall foundation/connection/column assembly.

In expectation, under seismic conditions, of a plastic hinge at the base of the column, the length of this plastic hinge finds some difficulties to be determined because of the uncertain effectiveness of the longitudinal reinforcement in the lap zone of the bars.

In any case the formation of the plastic hinge in a raised position over the lap length shall be avoided since for this position the displacement ductility of the column would be reduced. More reliable results and possibly a higher displacement ductility can be obtained moving upwards the lap zone so to leave a sufficient length of single (non overlapped) reinforcement at the base of the column, provided these lower bars are weaker and connected to the sockets with proper provisions that don't endanger their ductility.

Some solutions aim at the concentration of the plastic hinge within the joint gap beneath the column, under-proportioning the section of the fasteners. Also if ductile steel for fasteners is used together with proper bolting techniques, the limited length available in the joint for plastic deformations leads to a limited

plastic rotation, smaller than what obtainable by a flexural plastic deformation diffused for a bigger length in the column.

Proper reinforcement shall be placed in the foundation element around the fasteners against their pull-out and for the diffusion of the tensile stresses.

4.3.2 Strength

The connection shall be verified for the action of the (plastic) ultimate moment $M_{Rd}=M_{Rd}(N)$ at the base of the column with the correspondent contemporary axial force N and of the shear V . This calculation can be performed in the two main directions independently. For the calculation of the ultimate moment M_{Rd} the steel area of the lower bars or of the below (ductile) fasteners shall be assumed whichever gives the smaller force. The due overstrength factor γ_R shall be added as specified hereunder.

The lap length of the lower bars with the upper bars of the column shall be proportioned following Clause 8.7.3 of *EC2* applying the same factor γ_R and this calculation is taken for granted in the following points.

Due to their expected brittle failure modes, in general terms for a good ductile behaviour the local devices (sockets, bushes, bolts,...) with their coupling provisions (welding, threading, pressing,...) shall be over-dimensioned by γ_R with respect to the connected elements to which a ductile behaviour is required. This dimensioning is up to the producer of the connectors system and is taken for granted in the following points.

4.3.2.1 Behaviour models

Figure 4.3.2 shows the detail of the resisting mechanism of the foot section of the column subjected to the combined bending moment $\gamma_R M_{Rd}$ and axial action N and to the shear $\gamma_R V$. Assuming that at this level of action the tensioned lower steel bars or the steel fasteners (whichever is the weaker) are at their maximum ultimate capacity F_u , the anchorage verification shall be referred to a correspondent pull-out force.

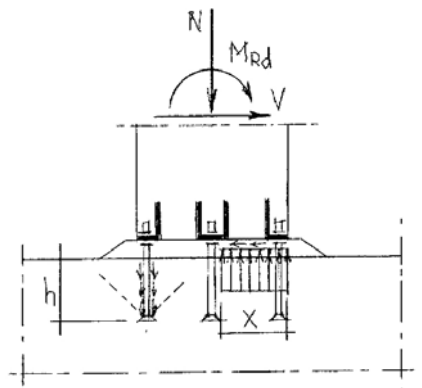

Figure 4.3.2

4.3.2.2 Failure modes

The failure modes are listed hereunder:

- a – failure of a non ductile fastener subjected to the tensile force coming from the upper reinforcement;
- b – pull-out of the head-fastener subjected to the maximum upper force F_u with concrete cone-failure;

c – sliding shear failure at the foot section in the design situation corresponding to $\gamma_R M_{Rd}$, N and $\gamma_R V$.

4.3.2.3 Calculation formulae

For fasteners well spaced among them and from the foundation edges, with reference to the symbols described in Figure 4.3.2 and with γ_R overstrength factor °, the following verifications shall be performed.

a – fastener failure (for non ductile fasteners)

(F_{Rmin} minimum steel ultimate capacity of the fastener declared by the producer)

$$F_{Rmin} \geq \gamma_R A_s f_{ym} \quad A_s \text{ sectional area of the corresponding upper reinforcement}$$

where

$$f_{ym} = 1,08 f_{yk} \quad \text{mean yielding stress of the steel bars (} f_{yk} \text{ their characteristic yielding stress)}$$

b – pull-out

($f_{ck,cube}$ characteristic compressive cubic strength of concrete, h effective length of the fastener, F_{Rmin} , A_s and f_{ym} defined before)

$$R_d \geq \gamma_R F_u \quad F_u = \min \{ A_s f_{ym}, F_{Rmax} \}$$

where

$$F_{Rmax} = 1,2 F_{Rmin} \quad \text{except differently declared by the producer}$$

$$R_k = k \sqrt[3]{f_{ck,cube} h^3} \quad (R_d = R_k / \gamma_C)''$$

and k may be taken from the relevant *ETS* (for current products the safe side value $k=7,0$ may be assumed).

b – sliding shear

(b width of the section, x depth of its compressed part, f_{cd} design compressive strength of the mortar or of the column concrete if lower, A_d area of the fasteners not yielded by the contemporary flexure and f'_{yd} their steel design yielding stress)

$$V_{Rd} \geq V \quad \text{with} \quad V_{Rd} = V_{dd} + V_{fd}$$

$$(V = V(\gamma_R M_{Rd}) \text{ is the shear corresponding to } \gamma_R M_{Rd})$$

where

$$V_{dd} = 1,3 A_d \sqrt[3]{f_{cd} f'_{yd}} \quad \text{dowel resistance of the resisting fasteners}$$

$$V_{fd} = 0,5 b x f'_{cd} \quad \text{sliding resistance of the compressed mortar or concrete}$$

$$f'_{cd} \approx 0,5 f_{cd}$$

° The values $\gamma_R=1,2$ for DCM and $\gamma_R=1,35$ for DCH are recommended by *EC8*.

“ The value $\gamma_c=1,5$ is recommended by EC2 (see also TS2).

4.3.2.4. Any other data

The above calculations shall be adapted to the possible different solutions of other connectors systems.

4.3.3 Ductility

Tests have been performed on three different arrangements of the connection with the results specified below.

The first arrangement was characterised by *weak fasteners* of ductile steel coupled with strong bars in the column. Failure occurred without relevant cracking of the column caused by the rupture of a fastener. The plastic deformation remained concentrated within the joint lap with an almost rigid rocking of the column. The measured displacement ductility factor has been

$$\mu_\delta \approx 2,2$$

The second arrangement was characterised by *weak bars* under the lap zone moved in an upper position. An early failure occurred due to the rupture of a defective welding of a socket just after the yielding limit of the bars, pointing out the importance of a correct coupling technology. A non ductile behaviour resulted because of this defect with a measured displacement ductility factor of

$$\mu_\delta \approx 1,3$$

The third arrangement was characterised by an *inverted sockets* position, welded to the fasteners and bolted to the bars. Failure occurred after the formation of a plastic hinge at the base of the column with large cyclic deformations and has been produced by the localised rupture of the bars at their bottom end close to the coupling device. The measured displacement ductility factor has been

$$\mu_\delta \approx 3,0$$

4.3.4 Dissipation

For the first arrangement with *weak fasteners*, cyclic tests performed on the overall assembly foundation-connection-column showed a **low dissipation** capacity. This behaviour is to be attributed to the fasteners with their limited plastic length.

For the second arrangement with *weak bars*, the early failure occurred during cyclic tests performed on the overall assembly foundation-connection-column didn't allow to measure any sensible dissipation. The classification as **non dissipative** connection refers specifically to the defective unit tested.

For the third arrangement with *inverted sockets*, cyclic tests performed on the overall assembly foundation-connection-column showed a dissipation sensibly higher than that of the first arrangement but still in the range of a **low dissipation** capacity. This behaviour is to be attributed to the column, but is affected also by the alternate opening of the base joint.

4.3.5 Deformation

In cyclic testing the ultimate drifts specified below have been reached:

- for the first arrangement with *weak fasteners* 4,4 % mainly due the plastic rotation concentrated in the joint lap;
- for the second arrangement with *weak bars* 2,0 % with no sensible signs of plastic deformations visible on the prototype;

- for the third arrangement with *inverted sockets* 4,5 % due to the column deformation and partly to the opening of the base joint interface.

4.3.6 Decay

Cyclic tests show that, for all the three arrangements, at any displacement level before failure no relevant strength decay displays after the three cycles.

4.3.7 Damage

For all the prototypes at serviceable limit state, taken as 1 % of drift, an elastic behaviour with no sensible residual deformations as been registered.

- For the first arrangement with *weak fasteners* the yielding limit set about at 2,0 % of drift. At 3,0 % of drift, with no relevant cracking in the column, a residual deformation of about 15 % at unloading was measured. Failure occurred at 4,4 % of drift with the rupture of fasteners and widespread cracking in the foundation element.

- For the second arrangement with *weak bars* the yielding limit set about at 1,5 % of drift. An early brittle failure occurred at about 2,0 % of drift due to the rupture of a defective welding of a socket.

- For the third arrangement with *inverted sockets* the yielding limit set about at 1,5 % of drift. At 3,0 % of drift relevant damage has disclosed by a widespread cracking of the column with about 30 % of residual deformation at unloading. Failure occurred at 4,5 % with the rupture of a bar at its threaded end, spalling of concrete at the base joint and a wide crack at the interface with the column.

4.4 FOUNDATIONS WITH BOLTED FLANGES

4.4.1 General

Figure 4.4.1 shows the scheme of the connection of a column to the foundation obtained through a steel plate (flange) attached at the column base and bolted to the foundation. The flange may be directly or indirectly jointed to the longitudinal reinforcing bars of the column by means of weldings and possible intermediate steel devices similar to those of Figure 4.3.1. The plate is subsequently attached to the anchor bolts protruding from the foundation element in the same way as for steel columns. For the anchor bolts common bars may be employed or special headed fasteners.

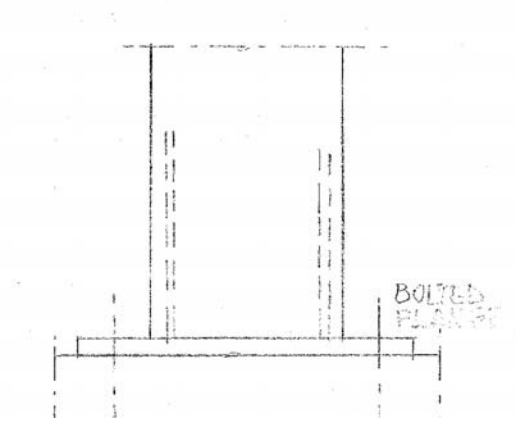

Figure 4.4.1

Between the plate and the foundation a gap can be left so to allow a better regulation of the column position, both in elevation and in verticality. At installation stage the column can be supported by lock-nuts screwed on the fasteners, by which its verticality can be adjusted and maintained without the need of provisional props. The installation is completed with the tightening of the upper nuts and the casting of the mortar embedding to fill the joint between the column base and the foundation.

This kind of connection is not very used and has not been tested within the SAFECAS Project. Some of the considerations of Points 4.3.1 and 4.3.2 are valid. In general, referring to the seismic behaviour, one can say that, to save the ductility properties of the column, early brittle failure of the welded and bolted parts of the connection shall be avoided. And this can be obtained by adequate execution techniques and by an over-proportioning with the capacity design criteria.

4.4.2 Strength

For the verification of the column base reference to *PT8* (see Clause 6.2.8) can be made. The jointing details between the flange and the longitudinal reinforcement of the column should be verified with the aid of testing.

4.4.3 Other properties

No specific parameters of seismic behaviour (ductility, dissipation, deformation, decay, damage) have been experimentally measured for this type of connection.

4.5 CONNECTIONS WITH MECHANICAL COUPLERS

4.5.1 General

This type of connection refers to over-designed mechanical devices that realize a moment-resisting support between a column and the foundation through high resistance bolts. The gap is filled in with high resistance no-shrinkage mortar to ensure the continuity with the members' concrete. The mortar shall have at least the same resistance of the concrete.

Fig. 4.5.1 shows the base connection of a column to the foundation. The reinforcing bars are connected to steel plates placed in each member. Bolts are inserted through the plates to joint the connection. In the case of Figure 4.5.1a the same coupling detail of Figure 3.3.2 has been adopted. In the case of Figure 4.5.1b four angle plates are used, each one connecting four bars through three bolts.

If the concrete section is sensibly weakened by slots for the installation of the bolts, it shall be restored and properly confined.

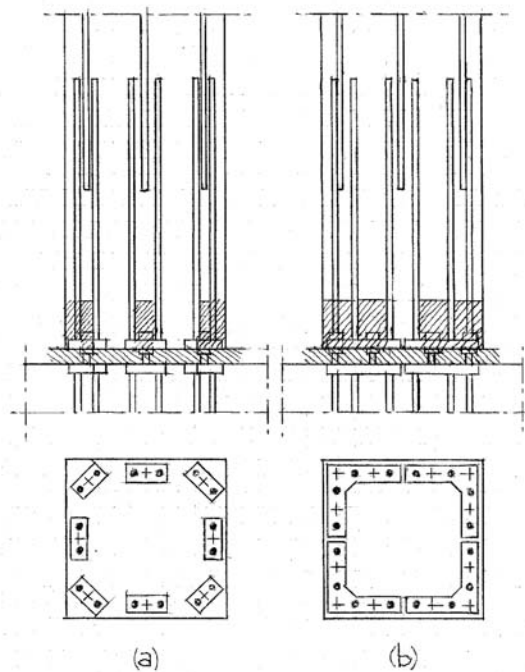

Figure 4.5.1

4.5.2 Strength

4.5.2.1 Behaviour models

This type of connection provides a clamped support. The bolts are mainly acting in tension. In some cases they can also act in compression (if a proper counter-nut is provided).

The longitudinal force due to the bending moment and axial action is directly transmitted to the reinforcing bars through the connection. The mortar filling act in compression.

4.5.2.2 Failure modes

The principal failure modes are listed hereunder:

- a – breaking of the coupler (bolt);
- b – excessive deformation of the supporting plates;
- c – detachment of the reinforcing bars.

4.5.2.3 Calculation formulae

This type of connection is placed in critical zone. For the action of a force evaluated by capacity design with respect to the greater between the resistance of the two reinforcements connected by the coupler using the due overstrength factor γ_R , the following verifications shall be made.

- a – coupler (non ductile)
assuming that the threaded length and the washers are correctly dimensioned, the coupler shall be verified as follows (F_{Rmin} minimum ultimate capacity of the steel coupler declared by the producer):

$$F_{Rmin} \geq \gamma_R A_s f_{ym} \quad A_s \text{ greater sectional area between the corresponding bars}$$

where

$$f_{ym} = 1,08 f_{yk} \quad \text{mean yielding stress of the steel bars } (f_{yk} \text{ their characteristic yielding stress)}$$

- b – plate(s)

the plate(s) thickness shall be over-proportioned in thickness in order to have negligible deformation at the connection failure.

- c – reinforcement

a proper anchorage between the bars and the plate(s) shall be designed by initial type testing; in case of direct welding, special care and controls are required to avoid the weakening of the reinforcing bars.

The values $\gamma_R=1,2$ for DCM and $\gamma_R=1,35$ for DCH are recommended by EC8.

4.5.2.4 Any other data

Being this type of connection over-designed, failure is expected to occur out of the connection in the jointed reinforcement. Since high strength bolts are usually adopted as couplers, their cross section can be smaller than the one of the bars they are jointing. This can lead to greater strain with the opening of concrete cracks also within the connection.

Special care is required for the mortar filling process, especially if dealing with complex three dimensional surfaces and small gaps.

4.5.3 Ductility

The ductility of the connected column is not affected by the connection that is over-proportioned and designed to remain in elastic field.

4.5.4 Dissipation

The energy dissipation at the base of the connected column does not depend on the connection itself. Local damage of the mortar or other local effects can create a permanent gap in the joint affecting the cyclic performance of the connection. Double counter-nuts are suggested to be used to reduce this effect making the bolts acting also in compression. High tightening moments can be applied to delay the decompression and the opening of the joint.

4.5.5 Deformation

A slightly larger flexural deformation of the column is expected with this type of connection, if compared to a cast-in-situ monolithic solution, due to the local elastic elongation of the couplers.

4.5.6 Decay

Cyclic tests show that at any displacement level before failure no relevant strength decay displays after the three cycles.

4.5.7 Damage

Failure is expected to occur out of the connection, while damage (cracking) includes also the joint.

5 CALCULATION OF ACTION

5.1 General criteria

In the preceding chapters the calculation of the resistance R_R has been presented for the different types of connections. The present chapter gives indications for the calculation of the action R to be compared to the corresponding resistance for the safety verification ($R_R \geq R$). In what follows it is assumed that for the structural analysis a method based on the response spectrum is applied (linear static elastic analysis or modal dynamic elastic analysis), where the energy dissipation effects at the no-collapse limit state are simulated by the behaviour factor q in line with EC8.

Ductile connections, as defined in Clause 0.5, may give or not a relevant contribution to the energy dissipation at the no-collapse limit state depending on their location in the structural assembly and relative stiffness. In general also ductile connections shall be over-proportioned by capacity design in order to divert the hysteretic plastic deformations into the critical regions able to display a determining energy dissipation for the structure. Specific indications are given in the preceding chapters with reference to the different types of connections. When at the no-collapse limit state the energy dissipation provided by the connections is determining, the proper relation $q=q(\mu)$ should be defined.

Brittle connections shall be verified for resistance with an action calculated through the analysis of the overall structural system with a behaviour factor $q=1$ or over-proportioning them with respect to the resistance of the critical sections of the structure through a reliable model of capacity design. The application of capacity design, using the due overstrength factor γ_R as specified in the preceding chapters, is the most reliable approach for the proportioning of such connections. Most of connections presently used in precast structure belong to this class.

5.2 Capacity design

In some cases the application of capacity design for the proportioning of the connections is simple and immediate. With reference to the beam-to-column connections of Figure 5.1, the shear force V at the top of the columns can be calculated from the resisting moment M_{rd} of the section at the critical region at the base of the columns with $V=M_{rd}/h$ so that, introducing a γ_R factor, the force on the connection becomes

$$H = \gamma_R V = \gamma_R M_{rd} / h$$

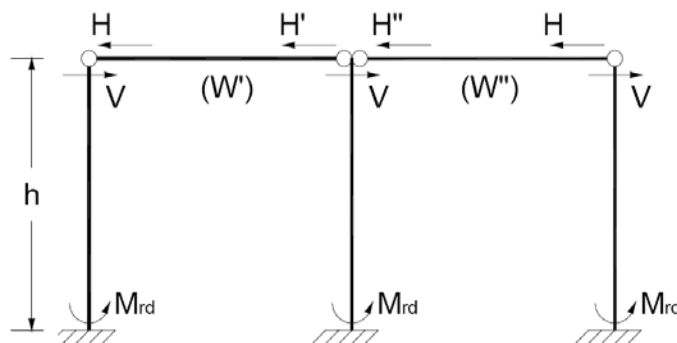

Figure 5.1

For an internal column the top shear force can be subdivided on the adjacent beams proportionally to the respective masses:

$$H' = \gamma_R V W' / (W' + W'')$$

$$H'' = \gamma_R V W'' / (W' + W'')$$

For multi-storey structure, such as the one of Figure 5.2, the equilibrium around the base support gives:

$$H_1 z_1 + H_2 z_2 + H_3 z_3 = \gamma_R M_{rd}$$

and the problem remains indeterminate depending on the ratio between the floor forces H_i . For not very flexible structures (with a natural vibration period indicatively lesser than 0,8 s), a linear increase of the floor forces with the height can be assumed:

$$H_2 = H_1 z_2 / z_1 \quad H_3 = H_1 z_3 / z_1$$

and this leads to

$$H_i = \gamma_R M_{rd} z_i / (z_1^2 + z_2^2 + z_3^2)$$

This evaluation may lead to under-estimate the force at the first floor.

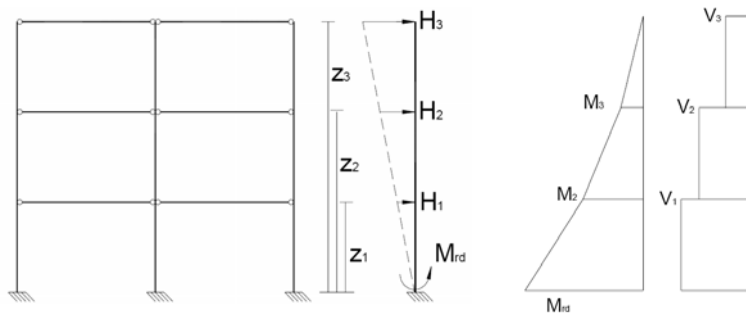

Figure 5.2

For more flexible structures the higher vibration modes become important and lead to a different distribution of the floor forces along the height. The most demanding distribution would correspond to opposite alternate forces at the different floors (see Figure 5.3b). This would lead to

$$H_i = V_i + V_{i+1}$$

where

$$V_i = \gamma_R (M'_{ri} + M''_{ri}) / h_i$$

with h_i height of the i^{th} floor and M'_{ri} , M''_{ri} resisting moments of the end sections of the included column. This model has full reliability, but it is excessively shifted to the safe side.

A more precise solution can be evaluated if, following a modal dynamic elastic analysis, the parameters of the first two vibration modes are available. From these parameters a random distribution of moments can be evaluated (see Figure 5.3c). The correspondent storey forces H_i are calculated modifying the values coming from the first vibration mode H_{i1} with a proper factor:

$$H_i = \varepsilon_i H_{i1}$$

$$\varepsilon_i = q \sqrt{\left[\min\left(\frac{M_{or} \gamma_R}{M_{o1} q}, 1\right) \right]^2 + \left[\frac{\Phi_{i2} \Gamma_2 S_e(T_2)}{\Phi_{i1} \Gamma_1 S_e(T_1)} \right]^2}$$

where

- Φ_{11}, Φ_{12} are the normalised story displacements of the 1st and 2nd vibration modes;
- Γ_1, Γ_2 are the participation factors of the 1st and 2nd vibration modes;
- and
- M_{or}/M_{o1} is the mean value of the ratios between the resisting moment and the correspondent 1st mode acting moment at the base of the columns.

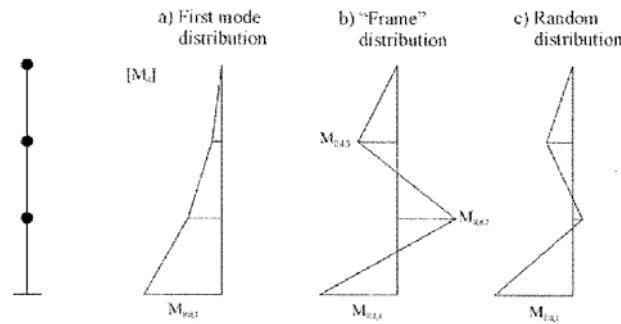

Figure 5.3

More complex is the application of capacity design to the connection system of a floor in its diaphragm function (floor-to-floor and floor-to-beam connections). The following example is aimed to give some indications in a simplified case.

Reference is made to a structural arrangement set on a regular orthogonal mesh with the columns placed on its nodes, the beams placed along one order of lines and the floor elements placed along the orthogonal order. Denoting by k the number of the floor bays, the total floor seismic force F_h will be shared on the $k+1$ orthogonal frames with ratios depending on the effectiveness of the floor diaphragm action. In case of absence of diaphragm action, assuming that the mass of each bay is subdivided into two equal parts on the adjacent frames, the internal frames would have a force $2F=F_h/k$ and the edge frames would have a half force $F=F_h/(2k)$. In case of a rigid diaphragm, assuming the same stiffness for all the frames, the total force F_h is equally subdivided on them, with $F=F_h/(n+1)$.

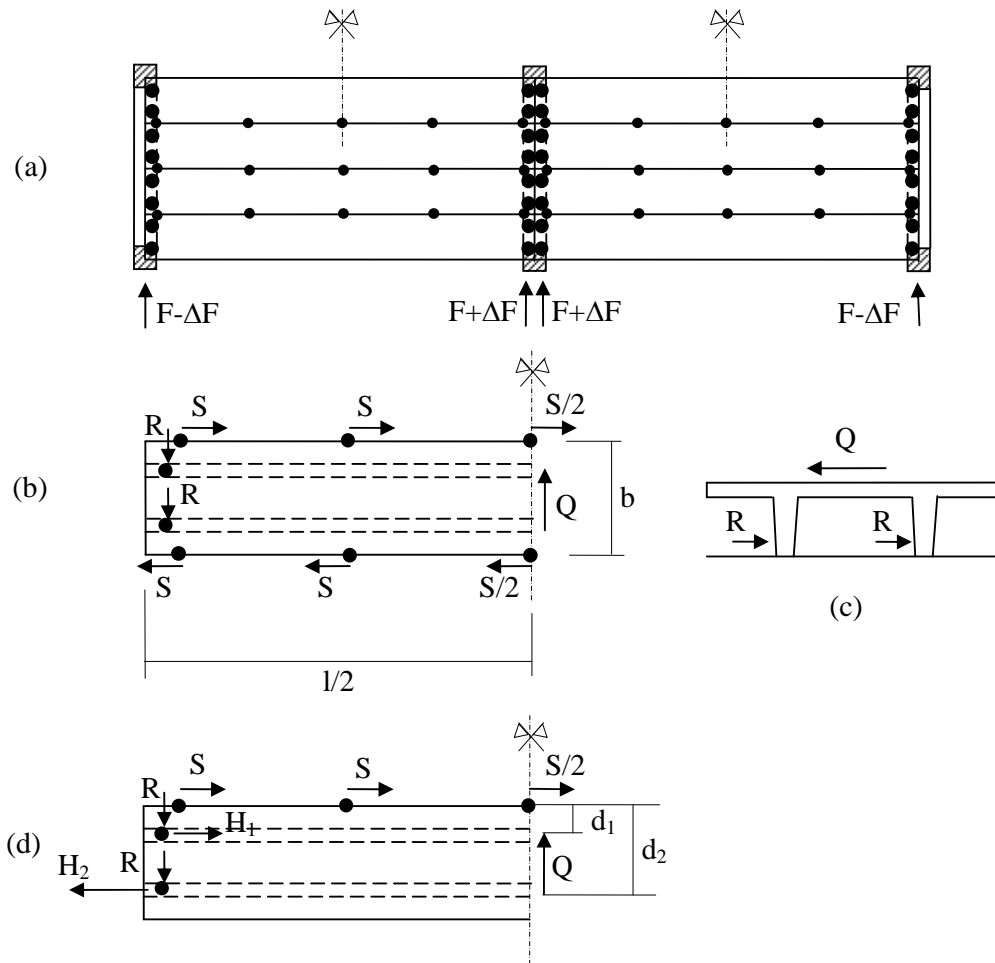

Figure 5.4

Therefore the diaphragm in-plane shear action transferred from the lateral to the internal frames can be calculated as the difference between the two extreme values:

$$\Delta F = F' - F = F_h (n - 1) / [2 k (k + 1)]$$

The maximum diaphragm shear force occurs in the case of two bays (Figure 5.4a): $\Delta F = F_h / 12$ and, with a safe side approximation, this could be the design value for all situations.

For one storey structure similar to the one of Figure 5.1, the total floor force at the ultimate limit state can be related to the flexural strength of the critical regions of the columns

$$F_h = \Sigma M_{rd} / h$$

where summation is extended to all the columns of the structure, assuming them contemporarily yielded.

For a continuous floor, consisting of precast elements joined with welded or bolted point connections, denoting by m the number of floor elements of one bay, on each single element a diaphragm force $Q = \Delta F / m$ would act, in addition to its own share of seismic force $F_o = F_h / m$. Equilibrated behaviour schemes are indicated in Figures 5.4b and 5.4d respectively for an internal and an edge element of the bay. From

the first of these schemes the following forces can be computed both for the lateral connections with the adjacent elements and for the two end connections with the supporting beam:

$$R = F_o / 2 + Q / 2$$

$$S = Q l / (n b)$$

Where l is the length of the element, b is its width and n is the number of connections of one edge. For the second scheme, which refers to the end element with one free edge, the following forces can be computed:

$$H_1 = (Q / 2) (1 - d_2 / b) / b_o$$

$$H_2 = (Q / 2) (1 - d_1 / b) / b_o$$

where d_1 and d_2 indicate the distance of the two end supports from the internal edge and $b_o = d_2 - d_1$ is their spacing.

These schemes save the force equilibrium and not the deformation compatibility and would require, to compensate the inaccuracy of this calculation, an adequate ductility of the connections, that is difficult to obtain. Alternatively an increased value of γ_R factor shall be used.

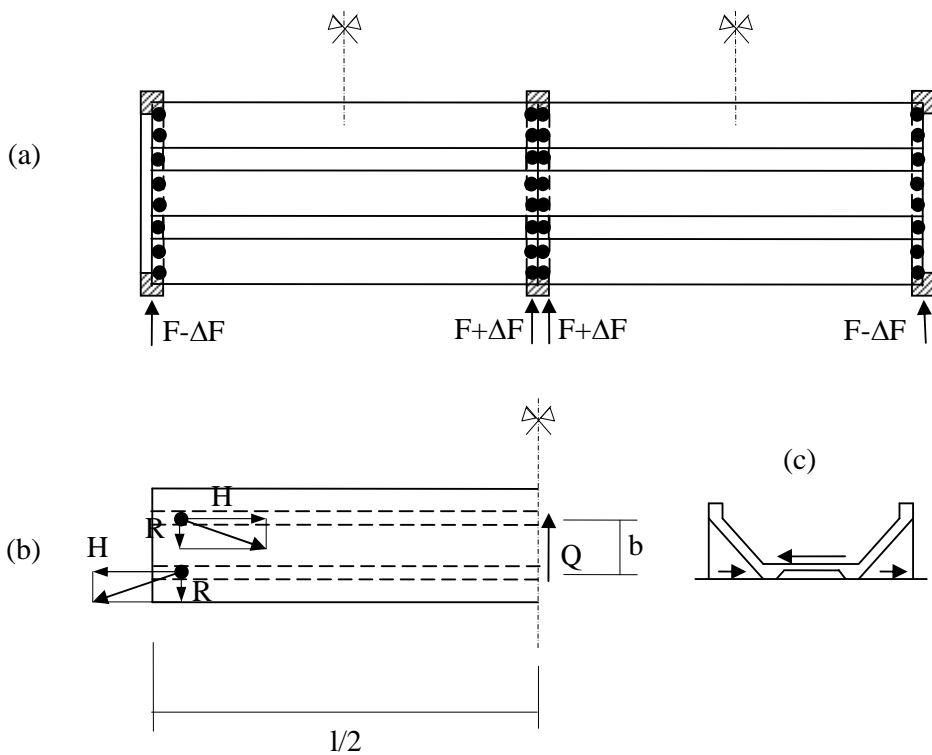

Figure 5.5

For a discontinuous roof, consisting on precast elements spaced to allow the positioning of skylights (Figure 5.5a), assuming a double support on thee beam able to restrain the horizontal relative rotation, the equilibrated scheme is represented in Figure 5.5b. The two component of the reaction can be calculated with:

$$R = F_o / 2 + Q / 2$$

$$H = Q l / (2 b_o)$$

The floor-to-beam connections can be designed with these forces in order to ensure, also for this type of discontinuous roof, a diaphragm behaviour that in general is sufficient for a controlled response of the structure.

The capacity design to column-to-foundation connections is directly applied as shown in Chapter 4.

Annex A – PROTOCOL FOR CONNECTION TESTING

The quantification of the properties listed in Clause 0.4 has been carried out by means of tests performed following the procedures described below. For a direct comparability of the results, the same procedures should be followed for the qualification of new types of connections.

A.1 Levels of tests

Generally speaking, four levels of tests are scheduled, addressed to different identification purposes as specified below:

-*particular tests* referred to the qualification of single connectors inserted between two over-proportioned blocks and subjected to the main action expected in the structural system;

-*local tests* referred to the qualification of the connection included between two significant portions of the elements, representing the structural arrangement and subjected to the relevant components of the action;

-*tests on subassemblies* referred to groups of connections inserted in structural parts representing the current construction framing and subjected to its specific actions;

-*tests on assemblies* referred to the connection system of a complete structure subjected to the typical seismic actions.

In the present Annex the tests on subassemblies and assemblies are not dealt with. Regarding particular and local tests, both monotonic loading and cyclic loading are described. All tests are carried out under displacement control.

A.2 Monotonic loading

In general from monotonic (push-over) tests diagrams force-displacement $f-d$ such as those of Figures 1a-b-c are deduced. These diagrams qualify the behaviour of the connector or of the connection according with the following definitions.

Figure 1a represents a *ductile behaviour* characterized by a relevant plastic deformation after the elastic phase. In particular the curve *i* represents a ductile *hardening behaviour*, the curve *s* represents a ductile *stable behaviour*, the curve *d* represents a ductile *softening behaviour*. The significant points of the diagrams are: the yielding limit d_y-f_y and the ultimate limit d_u-f_u . It can be added, if preceding the ultimate one, the serviceability limit d_a-f_a corresponding to the maximum allowable deformation of the joint, regarding its functionality.

Figure 1b represents a *brittle behaviour* without plastic deformation and with a failure before the serviceability limit. The reference point corresponds to the ultimate limit d_u-f_u .

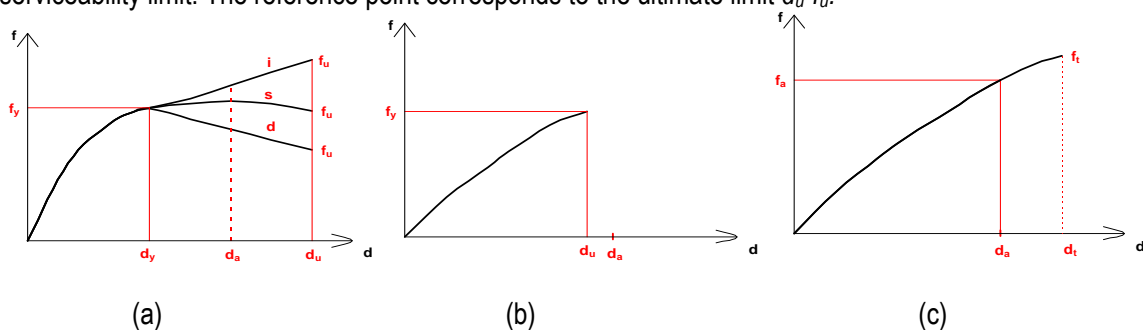

Figure 1. Diagrams – a ductile, b brittle, c over-resisting.

Finally, Figure 1c represents an *over-resisting behaviour* with the experimental curve stopped after the serviceability limit but before the yielding or ultimate limit. The reference points are the serviceability limit d_a-f_a and the test limit d_t-f_t .

The ductility deduced from the experimental behaviour is given mainly by the plastic resources of the steel connector with prevalent flexural deformations. Non linear effects may originate also from other phenomena like friction, material damaging and geometrical changes due to the large deformations of the connector.

The standard test includes an initial cycle taken up to the serviceability limit d_a-f_a , with unloading for the determination of the residual displacement d_r (see Figure 3). The final loading will follow, unless obviously an early failure occurred.

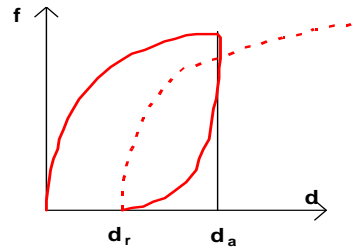

Figure 2. Initial cycle.

In addition to a first quantification of the constitutive parameters, the push-over test is performed also as preliminary, in order to define the loading steps of the subsequent cyclic test.

The monotonic test report shall include:

- Test title, laboratory and date
- Drawings of specimen and test setup
- Data to define geometrical and material properties
- Graphic representation in quoted reticulated diagram of the $f-d$ obtained curve
- Residual displacement d_r of the initial cycle
- Numerical values of the singular points on the final load curve
- Maximum force f_{max} achieved in the test
- Modality of failure and indication of the failing member or the preventive stop of the test
- Numerical value of the ductility coefficient $\mu=d_u/d_y$ or the limit $\mu>d_t/d_y$ (ductile behaviour)
- Every relevant additional information (such as occurrence of friction)

Such prescriptions can be modified or integrated according with the specific outcome of the test. A record of the whole test (raw data) has to be kept for further investigation.

A.3 Cyclic loading

The experimental cyclic response is obtained by applying the load history described in Figure 3, where groups of three cycles of the same amplitude are performed step by step with subsequent increments Δd up to the ultimate or test limit. The amplitude d_1 of the first initial group is taken as 1/4 of the lesser between d_y , d_a , d_t and d_u . The amplitude increments Δd of the subsequent groups of cycles are taken equal to d_1 . In these definitions the values are those obtained from the monotonic test performed on a similar prototype. The incremental loading process can be taken up to failure. In case of ductile behaviours, after 8 groups of cycles the increment Δd can be increased.

From the cyclic test one obtains diagrams force-displacement $f-d$ like that of Figure 4. They qualify the behaviour of the connector or of the connection according with the following definitions.

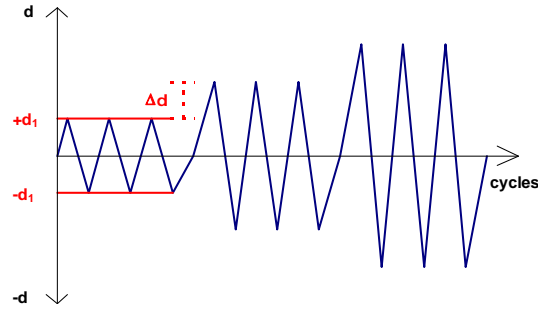

Figure 3. Loading history of the cyclic test.

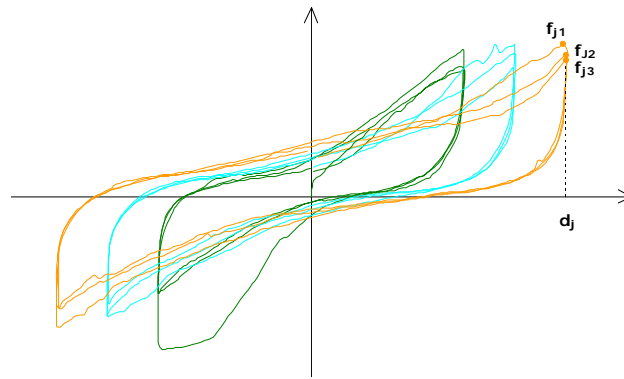

Figure 4. Force-displacement cycles

For non perfectly elastic behaviour, from the f - d diagram the histogram of dissipated energy U_i is calculated as the area of the corresponding i^{th} branch of the f - d diagram (see Figure 5a). The same histogram is converted in dimensionless form (see Figure 5b) dividing any area by the one corresponding to the perfect elastic-plastic half-cycle (see Figure 6):

$$u_i = U_i / U_{oi}$$

where

$$U_{oi} = d_{pi} f_{imax} \quad \text{with} \quad d_{pi} = d_i - d_{ei}$$

and where d_{ei} is calculated on the base of the inclination $k_1 = f_1/d_1$ of the initial branch of f - d diagram

$$d_{ei} = f_{imax} / k_1$$

If the f - d diagram does not show an elastic behaviour, the reference area for each half-cycle can be calculated according to a perfect rigid-plastic diagram (see figure 7):

where

$$U_{oi} = d_i f_{imax}$$

On the cyclic diagram the envelope curve shall be plotted starting from the initial part of the diagram.

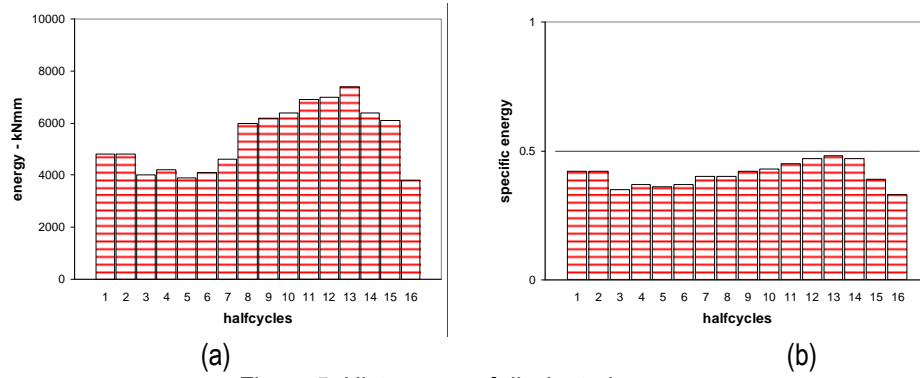

Figure 5. Histograms of dissipated energy

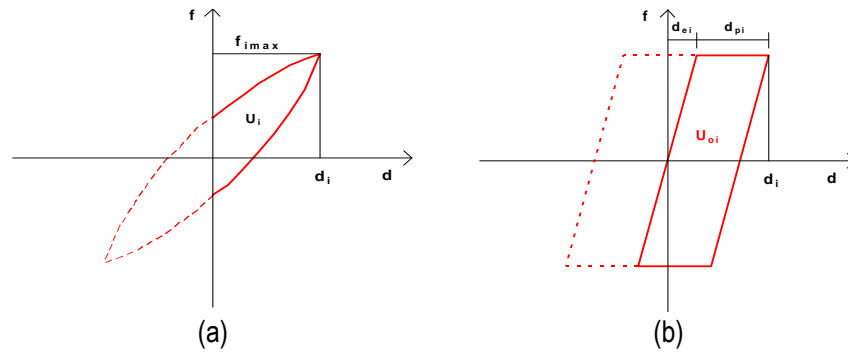

Figure 6. Numerical definition of dissipated energy (for elastic-plastic behaviour)

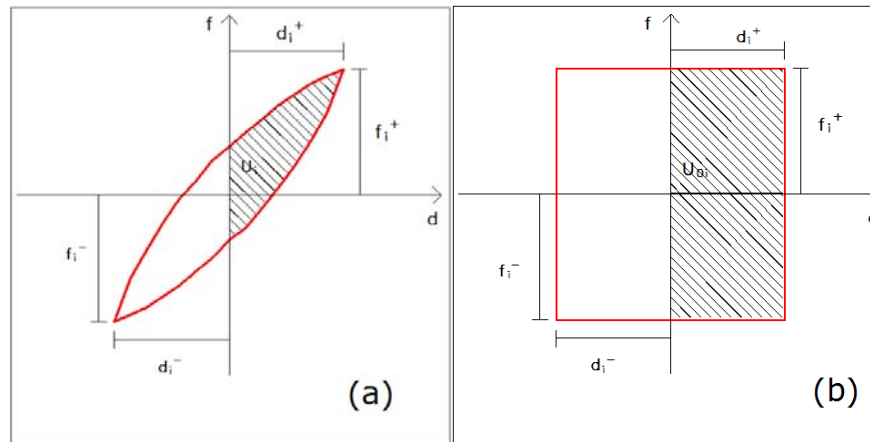

Figure 7. Numerical definition of dissipated energy (for totally inelastic behaviour)

The cyclic test report shall include:

- Test title, laboratory and date
- Drawings of specimen and test setup
- Data to define geometrical and material properties
- Graphic representation in reticulated diagram of the $f-d$ obtained cycle curve
- For any semi-cycle i : the displacement d_i , the maximum force $f_{i\max}$ and the specific energy u_i
- For any group j of semi-cycle the specific degradation $(f_{j1}-f_{j3})/f_{j1}$ of the force between the first and third cycle

- Modality of failure and indication of the failed member or the early stop of the test
- Numerical value of the ductility coefficient $\mu=d_u/d_y$ or the limit $\mu>d_u/d_y$ (ductile behaviour)
- Every relevant additional information (such as occurrence of friction)

Such prescriptions can be modified or integrated according with the specific outcome of the test. A record of the whole test (raw data) has to be kept for further investigation.

European Commission
EUR 25377 – Joint Research Centre – Institute for the Protection and Security of the Citizen

Title: Design Guidelines for Connections of Precast Structures under Seismic Actions

Author(s): Paolo Negro, Giandomenico Toniolo

Luxembourg: Publications Office of the European Union

20xx – xx pp. – 21.0 x 29.7 cm

EUR – Scientific and Technical Research series – ISSN 1831-9424

ISBN 978-92-79-25250-1

doi:10.2777/37605

Abstract

This document has been drafted within Work-Package WP6, "Derivation of design rules" of the project SAFECAST (Performance of Innovative Mechanical Connections in Precast Building Structures under Seismic Conditions), Project FP7-SME-2007-2 Programme – Grant Agreement n. 218417, 2009).

The provided guidelines have a theoretical derivation supported by the experimental results of the testing activities and the numerical simulations performed as a part of the project as well as by the general know-how on production practice and international literature on the subject.

As the Commission's in-house science service, the Joint Research Centre's mission is to provide EU policies with independent, evidence-based scientific and technical support throughout the whole policy cycle.

Working in close cooperation with policy Directorates-General, the JRC addresses key societal challenges while stimulating innovation through developing new standards, methods and tools, and sharing and transferring its know-how to the Member States and international community.

Key policy areas include: environment and climate change; energy and transport; agriculture and food security; health and consumer protection; information society and digital agenda; safety and security including nuclear; all supported through a cross-cutting and multi-disciplinary approach.